

*May 1999*

Summary of  
**Operating Experience**  
in Swiss Nuclear Power Plants

**1998**

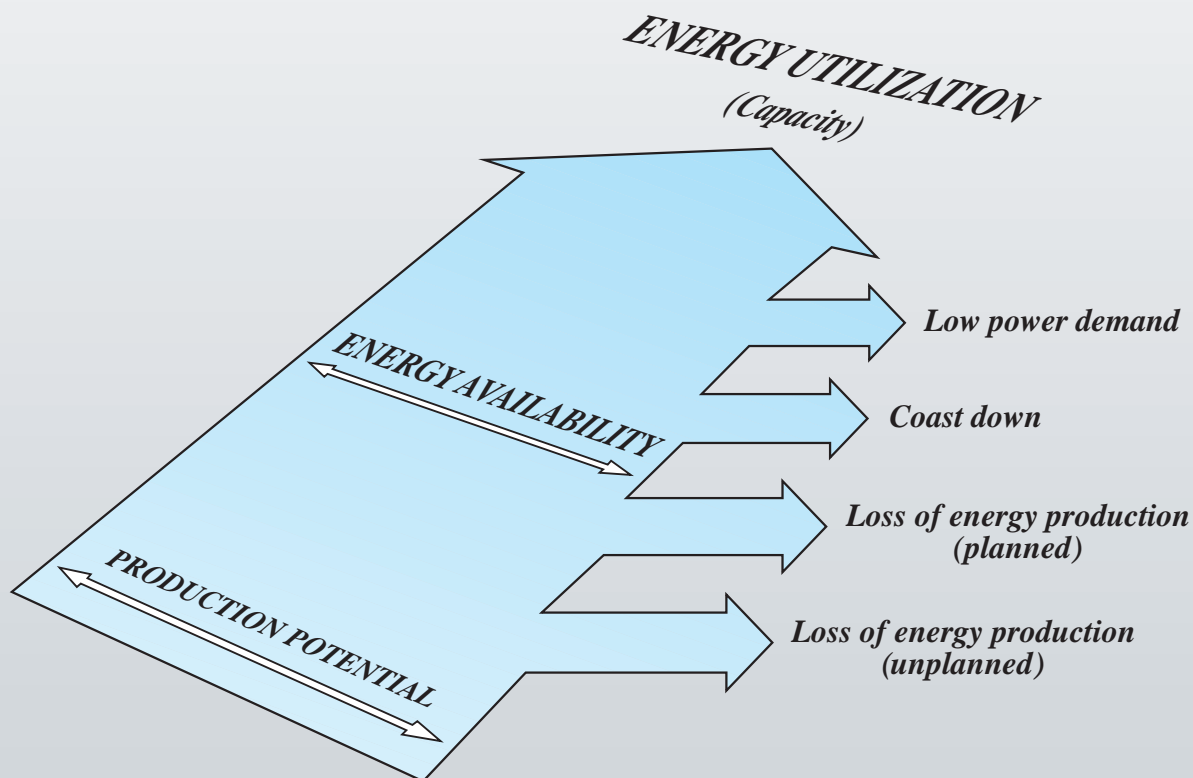



## SWISS NUCLEAR POWER PLANTS

Power station	Type of reactor	Net output (MWe)	Commercial operation
Beznau (KKB)	PWR	365 357	Unit 1: Dec. 24, 1969 Unit 2: March 15, 1972
Mühleberg (KKM)	BWR	355	November 6, 1972
Gösgen (KKG)	PWR	970	November 19, 1979
Leibstadt (KKL)	BWR	1080 <sup>1</sup>	December 15, 1984

<sup>1</sup>as of January 1, 1999

## DEFINITIONS

(Corresponding to the UNIPED classification «Statistical Terminology Employed in the Electrical Supply Industry»)

Energy availability factor – Etg/En  
(UNIPED definition 4.6.03.f)

Energy utilization factor – Ed/En  
(UNIPED definition 4.5.01)

En (*Production Potential*)

– energy producible assuming maximum capacity continuously available throughout a specific period

Ed (*Energy Utilization*)

– energy actually produced within a specific period

Etg (*Energy Availability*)

– energy producible assuming available capacity

The five Swiss nuclear power units produced a net total of 24.45 TWh of electricity in 1998 – a new record, and the second time that the 24 TWh milestone has been surpassed. The nuclear share in overall electricity production was 40%, also somewhat higher than the previous year's figure.

Several factors contributed to the excellent 1998 results:

- Plant operation was practically undisturbed. This reliability reflects the careful maintenance which goes in to keeping the plants in excellent condition.
- The efforts made over the last few years to increase plant productivity once again reaped their rewards.
- Refuelling and maintenance outages were short.

Concerning the final point: the Leibstadt outage lasted 26 days, the shortest annual outage since the plant first entered operation. Outage times for the other units were: Gösgen – 24 days; Beznau-2 – 41 days; Mühleberg – 35 days. Due to the 18-month cycle at Beznau-1, there was no refuelling outage there in 1998.

At Gösgen, Mox fuel was loaded for the second time in 1998. Of the 44 freshly loaded fuel elements, 20 were Mox elements. At Beznau-2, four Mox elements were newly loaded in 1998.

Deliveries of non-electrical energy by the Beznau and Gösgen nuclear power plants functioned flawlessly. Beznau fed 151 GWh of heat energy into the Refuna district heating system, while Gösgen supplied 153 GWh of process heat to the neighbouring Niedergösgen cardboard factory.

On October 21, 1998, the federal government issued licences both for a 15% increase in reactor power output at Leibstadt and for continued operation of the Mühleberg nuclear plant beyond the year 2002, but with a limit of 2012.

Swiss Association for Atomic Energy (SVA)

Dr Hans Jörg Huber, President

Dr Peter Hählen, Secretary General

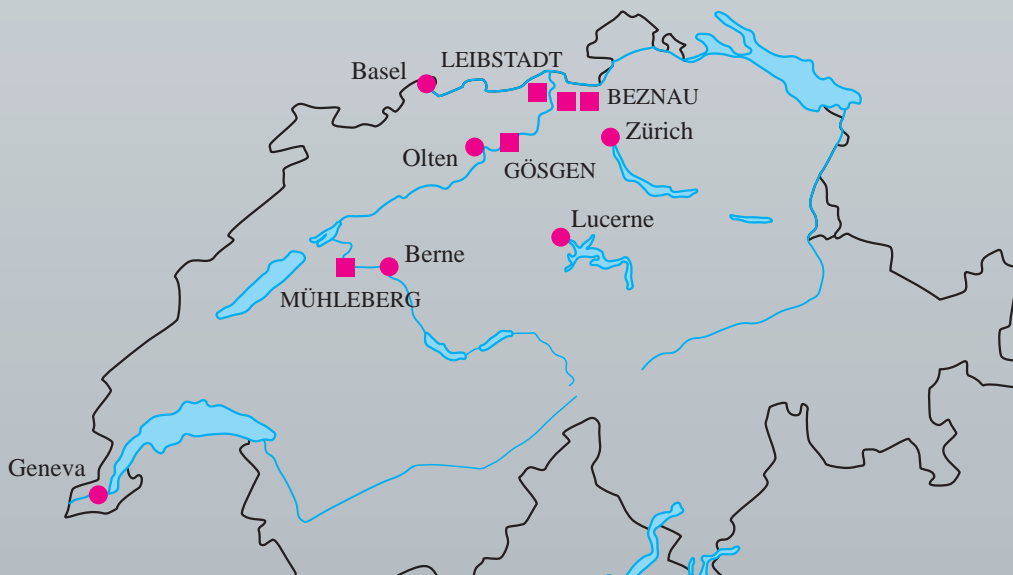

# Swiss Nuclear Power Plants: Production Figures 1998 and History

	Gross production MWh	Net production MWh	Total operating time (power production) h	Total gross production since start of operation MWh	Total net production since start of operation MWh
KKB 1	3 317 192	3 183 126	8760	75 235 139	71 945 937
KKB 2	2 836 400	2 717 822	7785	75 181 790	72 018 663
KKM	2 777 440	2 659 694	7886	67 376 733	64 295 906
KKG	8 292 090	7 839 730	8179	147 155 510	138 784 886
KKL	8 473 325	8 046 205	8139	111 575 769	105 577 367

## Energy Availability

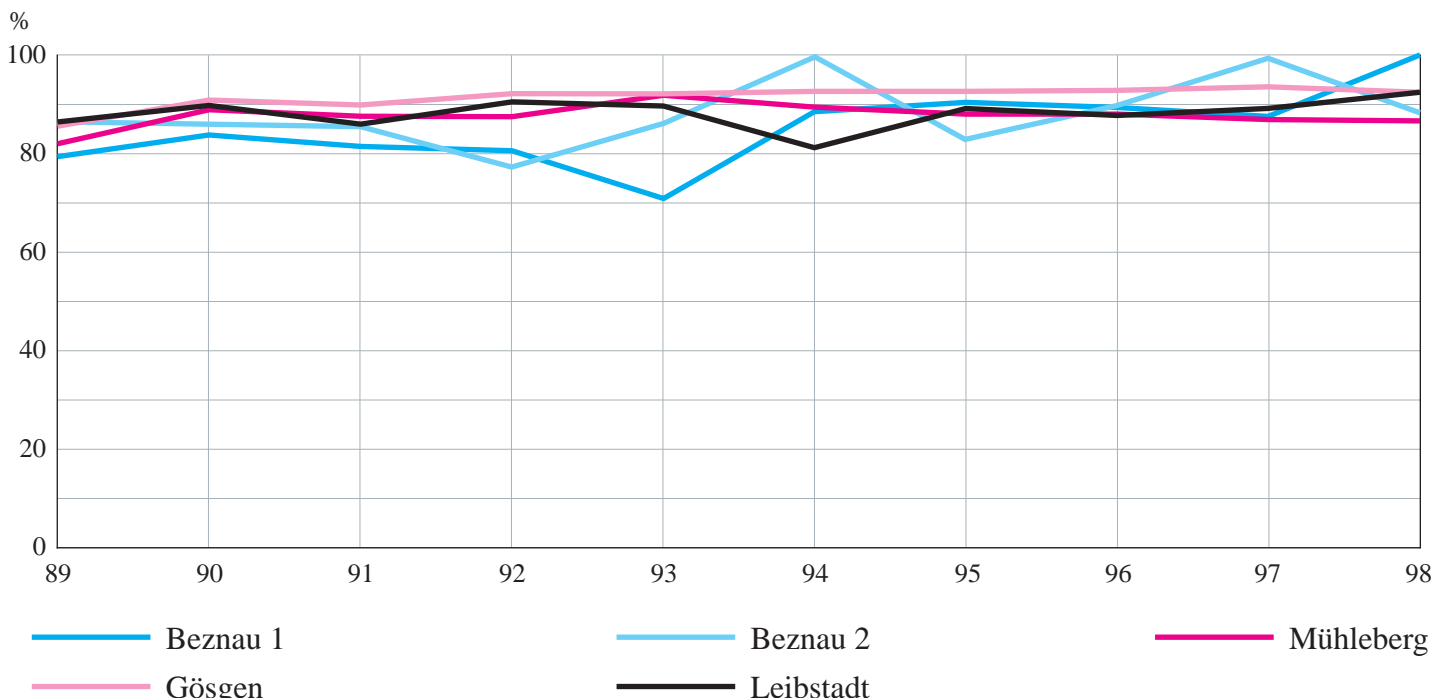

## Collective Exposure

Man-Sievert (Sv)

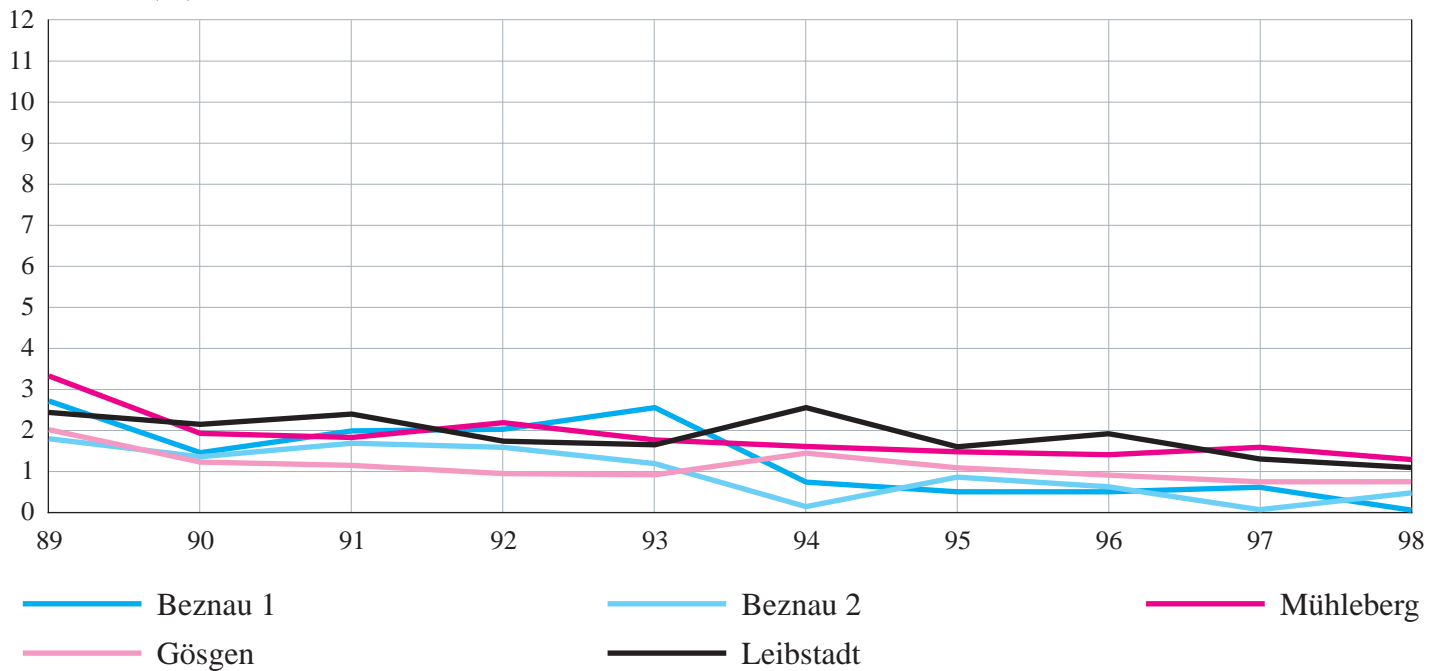

## Reactor Scrams

Number

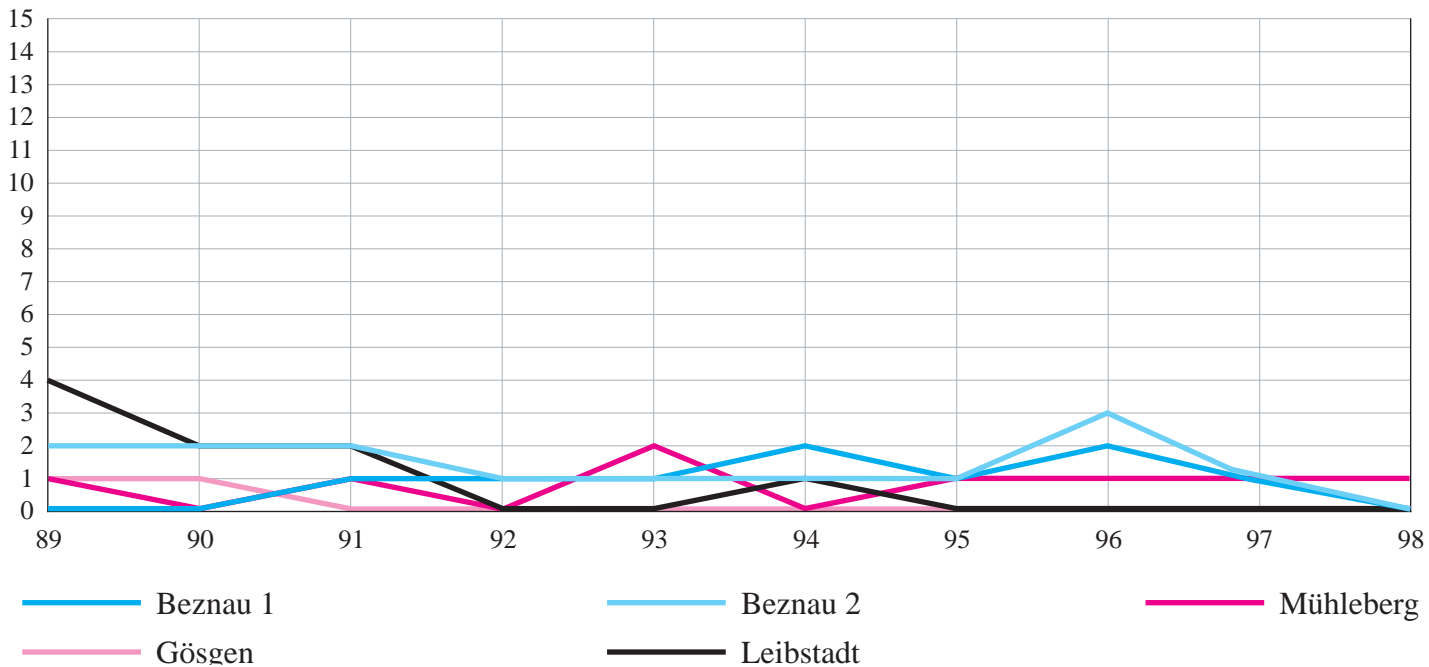

# Beznau 1

## Operating Experience 1998

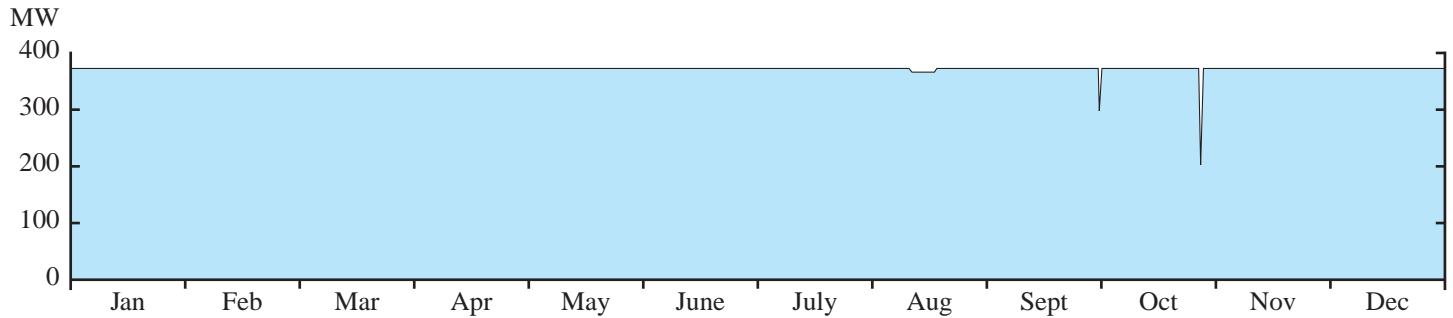

### Important to Safety

#### Scrams:

No scrams.

#### Other:

February 16 to 20: An OSART follow-up visit took place. The purpose was to determine the status of all proposals for improvement, to comment on the appropriateness of the actions taken and to make judgements on the amount of progress achieved. The final statistical analysis of the status of the recommendations and suggestions identified during the OSART mission in November 1995 revealed that 57% were resolved, in 38% of cases the plant made satisfactory progress, there was insufficient progress 2% of the time, and 3% were withdrawn.

### Important to Availability

**August 10 to 18:** Several minor load reductions due to high river water temperature.

**September 30:** Load reduction (cut-back) during I&C maintenance activities.

**October 25:** Load reduction due to turbine control disturbance.

**No refueling** at Beznau 1. The next refueling outage takes place in March/April 1999 (18-month cycle).

# History

# Characteristics

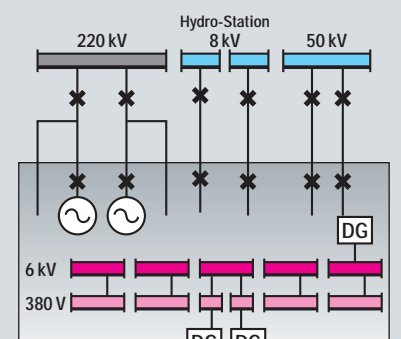
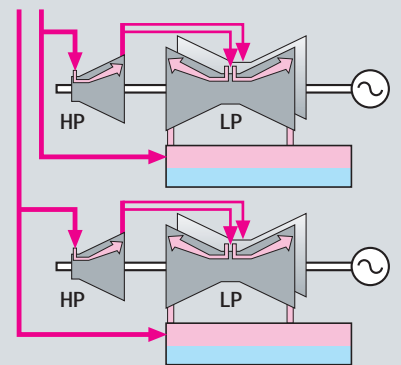
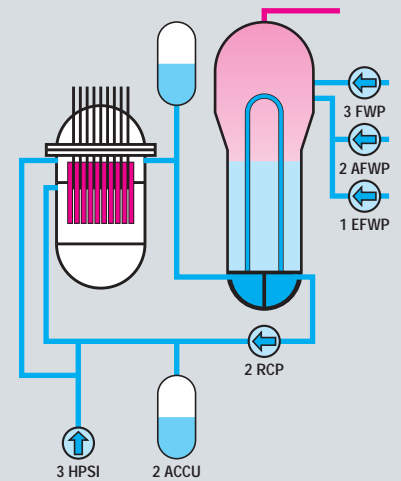
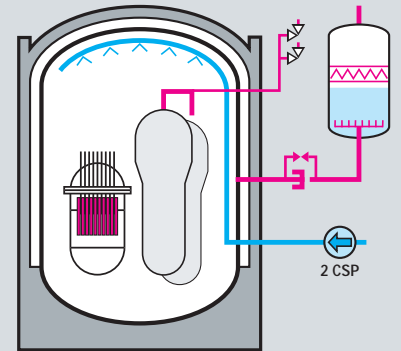
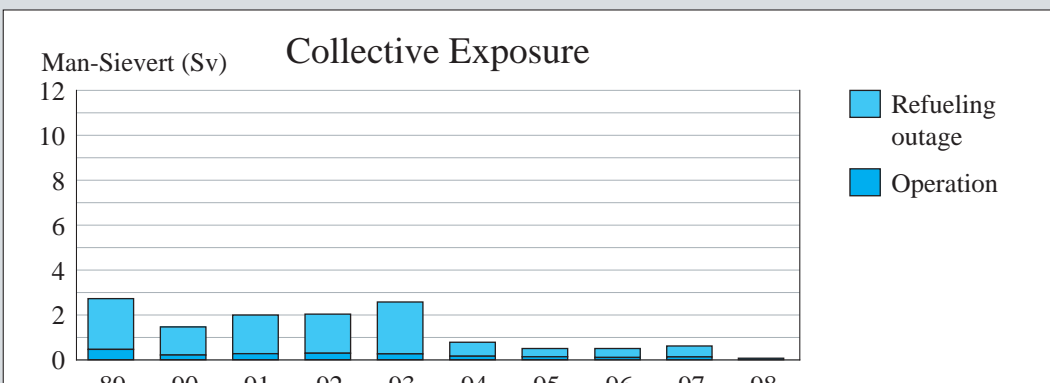
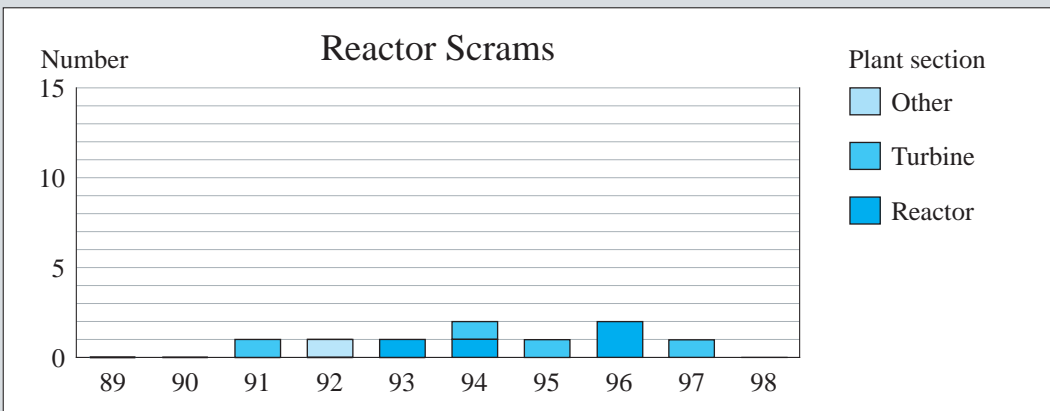
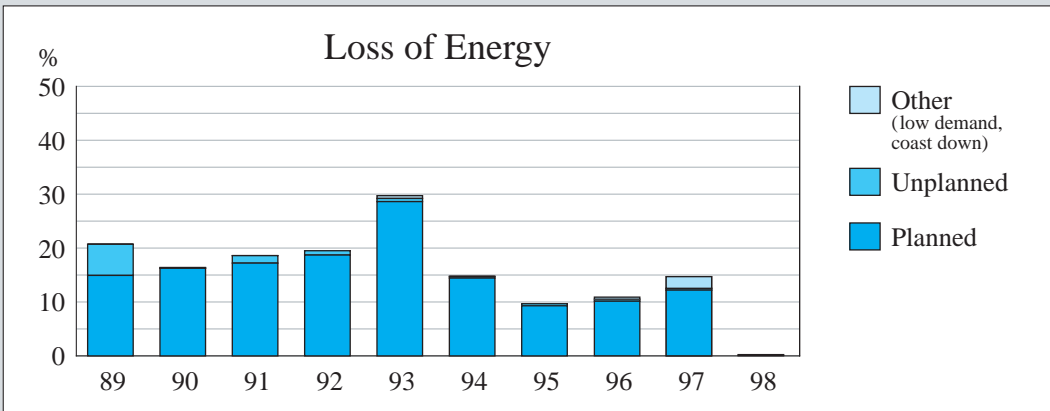
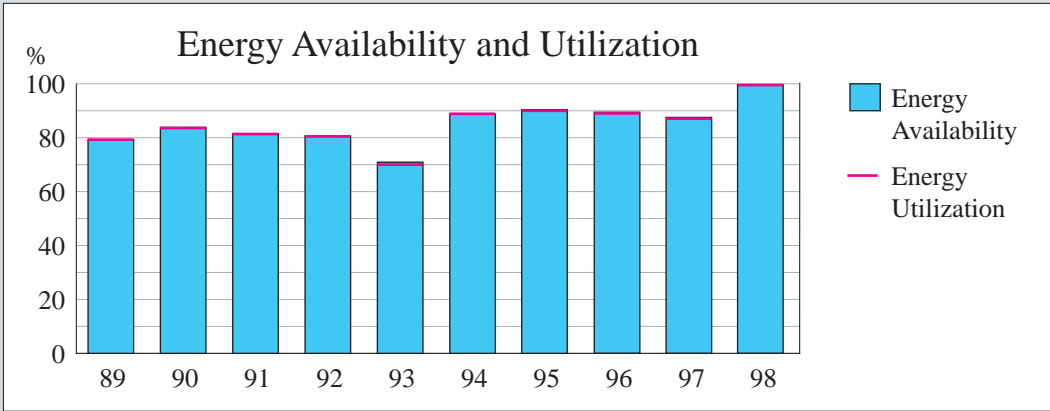

# Beznau 2

## Operating Experience 1998

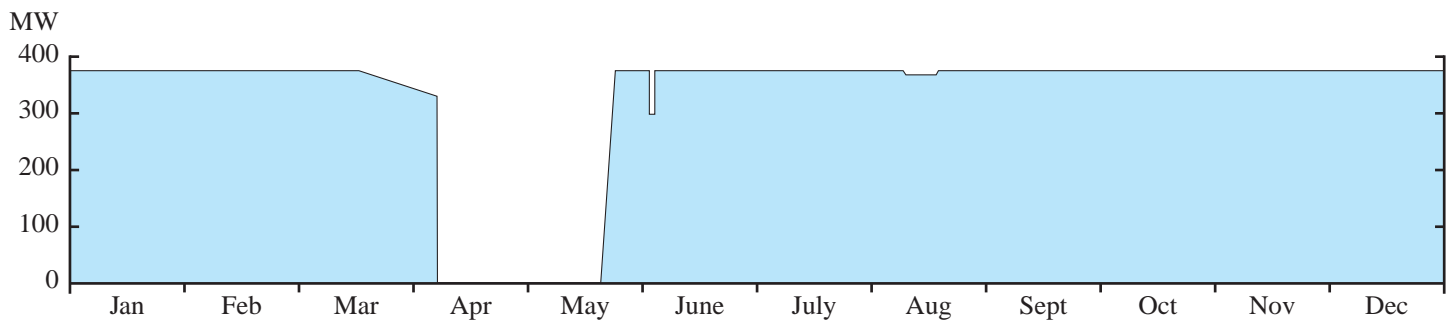

### Important to Safety

#### Scrams:

No scrams.

#### Other:

**February 16 to 20:** An OSART follow-up visit took place (see report on unit 1).

**April 6 to May 17:** During the refueling outage, an extended inspection program was carried out involving the reactor vessel head and the steam generators.

### Important to Availability

**March 16 to April 6:** End-of-cycle coast-down due to core reactivity reduction. Eventually, the power level dropped to 86%.

**June 3 and 4:** Load reduction due to maintenance on a turbine condenser.

**August:** Several minor load reductions due to high river water temperature.

#### Main outage activities:

- Replacement of 32 fuel elements (4 Mox elements).
- In-service inspection of reactor vessel head and steam generator tubing.
- Replacement of nuclear instrumentation (source range and intermediate range) by wide range detectors and digital electronic equipment.
- Replacement of the auxiliary transformers and the generator exciter systems.

# History

## Energy Availability and Utilization

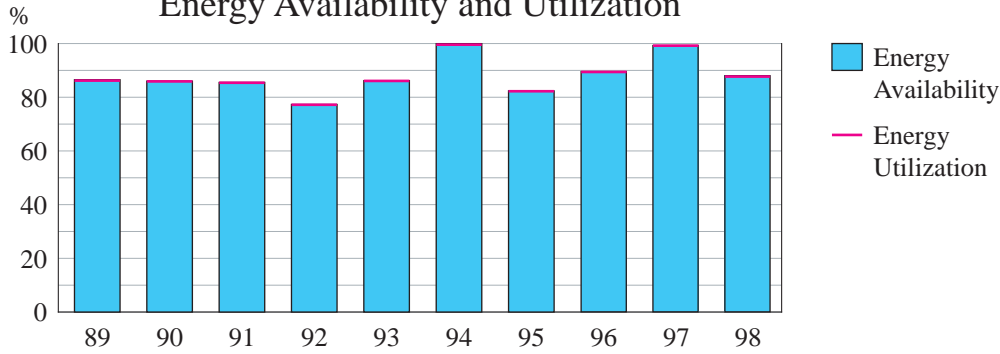

## Loss of Energy

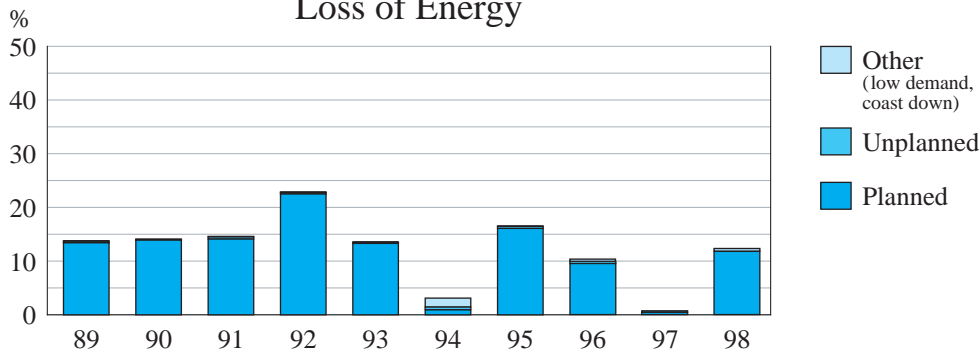

## Reactor Scrams

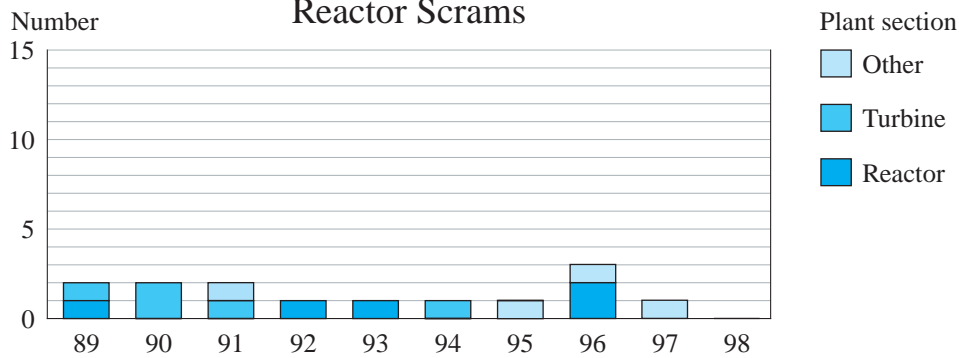

## Collective Exposure

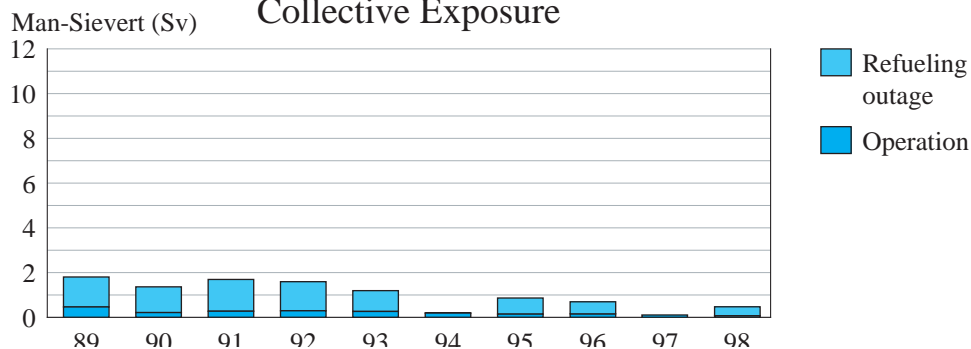

# Characteristics

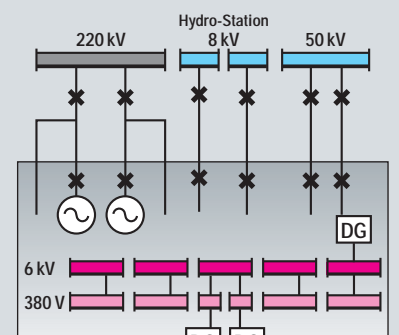
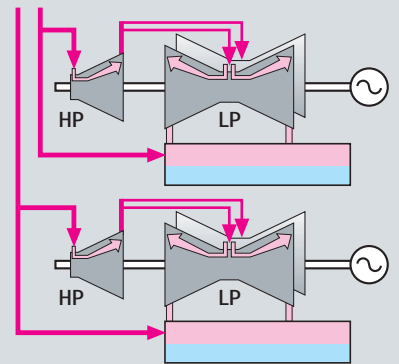
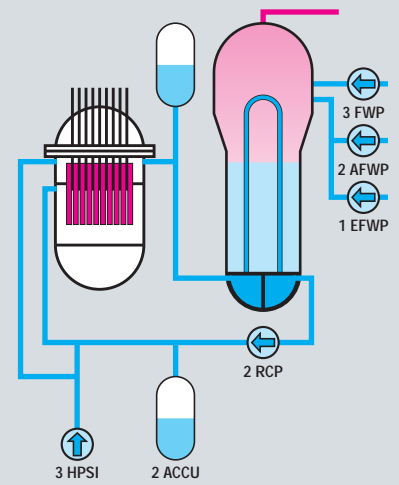
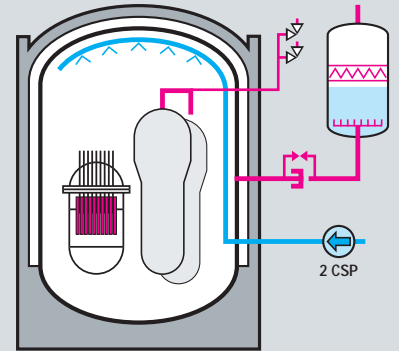

# Mühleberg

## Operating Experience 1998

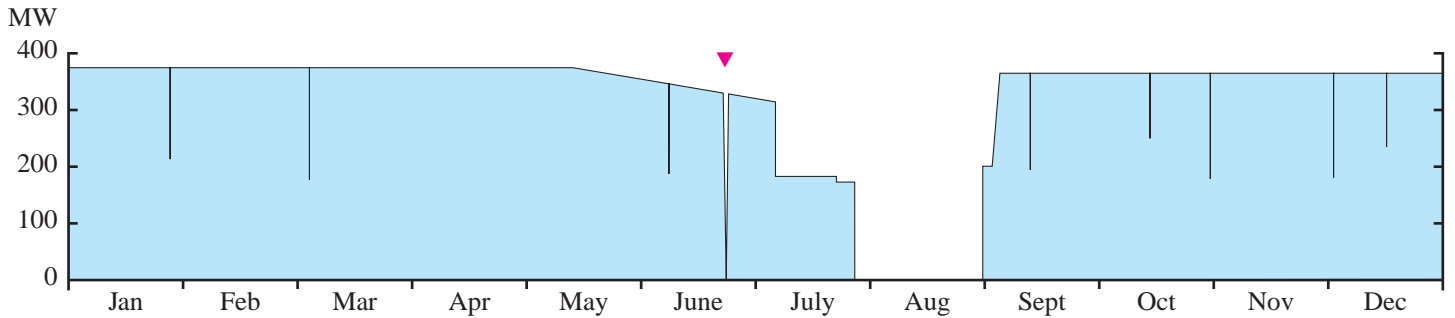

### Important to safety

#### Scrams:

▼ **June 23:** While performing a periodic test, an operator erroneously opened a safety relief valve. The counter-measures taken by the operating shift did not allow the safety relief valve to be closed quickly enough. The resulting steam flow caused a water temperature increase in the wetwell. As a result, a scram occurred when the wetwell high temperature scram set point was reached.

### Important to availability

**May 15:** The planned coast-down operation began.

**July 5:** The power level reached 83% and load was reduced to 50%. Turbine A was shut down to begin the planned condenser retubing. The brass tubes were replaced by titanium bulk tubes and stainless steel boundary tubes.

**July 21:** A slight load adaptation was needed to conform to the temperature limit of the condenser cooling water outlet.

#### Refueling outage, July 27 – August 31:

The planned outage lasted 35 days. The reactor manual control and the rod position indication systems were replaced. Six out of 57 control rods were replaced by new ones. Besides periodical in-service inspections, extensive ultrasonic inspections of reactor pressure vessel weldings were successfully performed.

40 out of 240 fuel elements were replaced by new ones.

#### Load reductions:

A total of nine load reductions (> one full power hour) was required.

Two unplanned load reductions occurred: one was due to an air-break in condenser A, while the other was caused by a failure during testing of the turbine A trip system.

Three planned load reductions to 50% were required for periodical surveillance tests. Three additional load reductions were necessary to change the control rod patterns. On July 5, the load was reduced to 50% for the planned shut-down of turbine A.

# History

## Energy Availability and Utilization

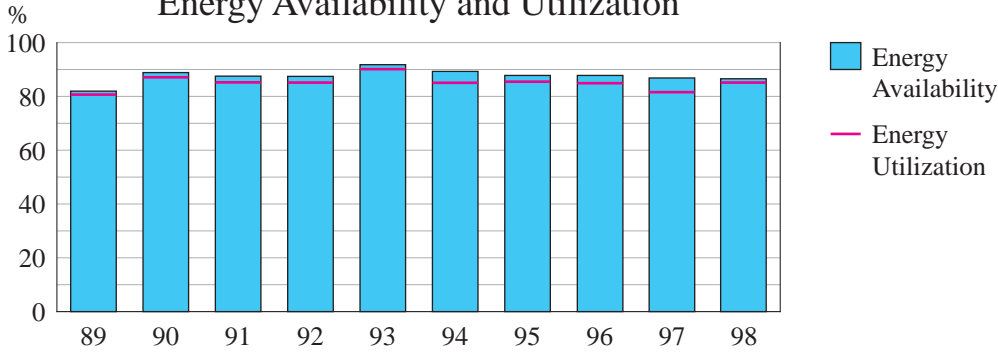

## Loss of Energy

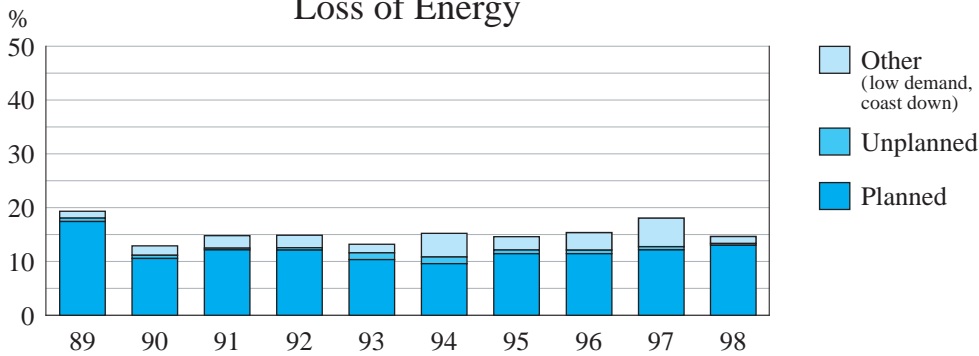

## Reactor Scrams

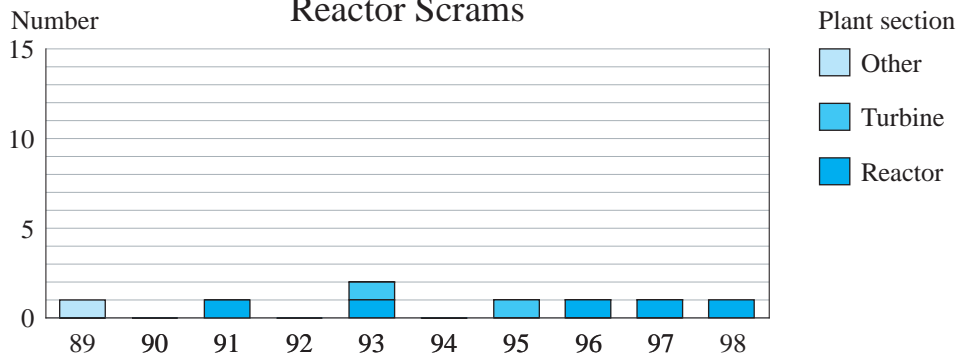

## Collective Exposure

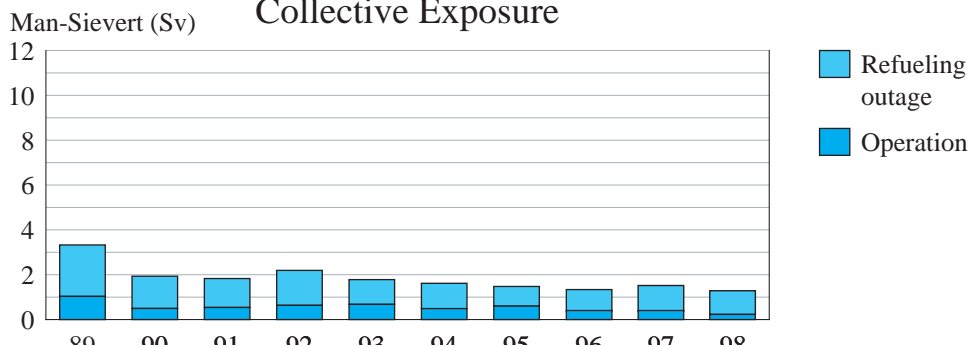

# Characteristics

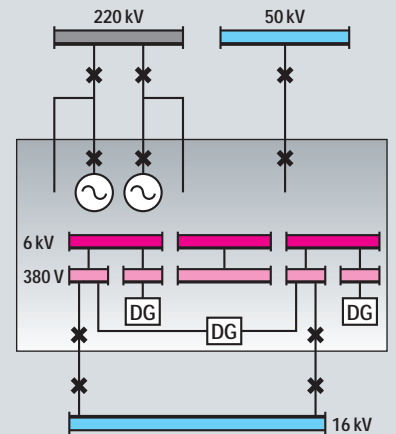
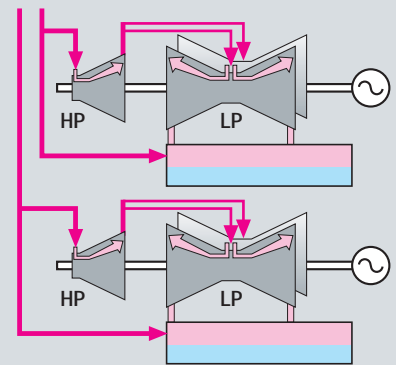
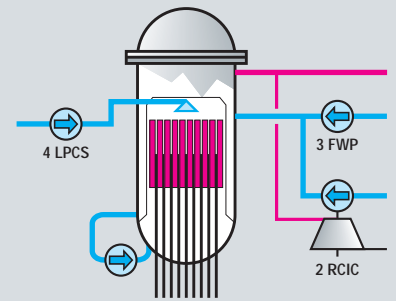
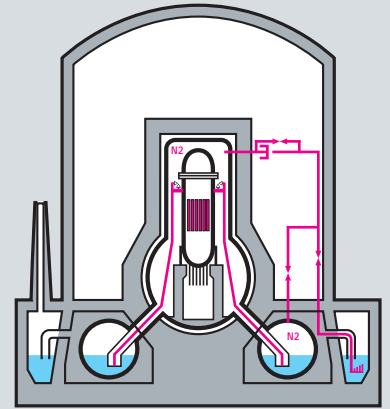

# Gösgen

## Operating Experience 1998

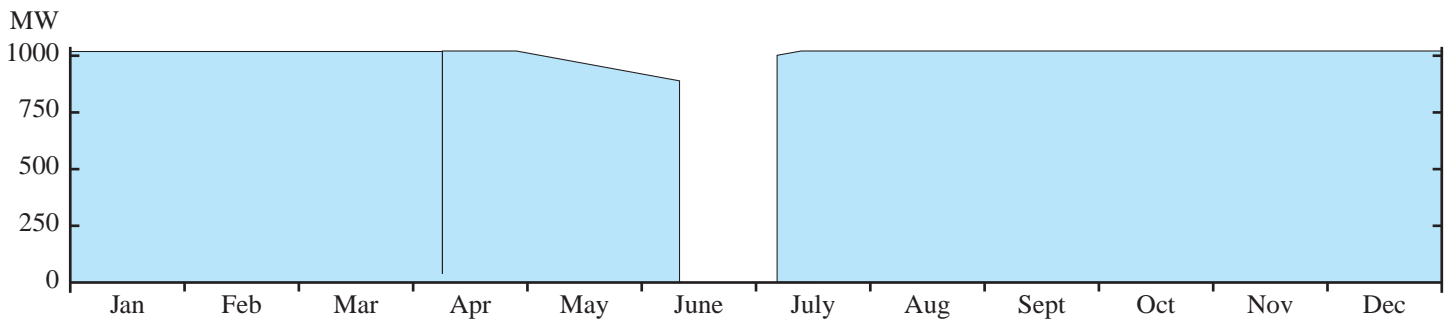

### Important to Safety

#### Scrams:

▼ **1998** was the eighth consecutive year of operation without any unplanned scrams.

#### Other:

**April 8:** During full power operation, when work was being carried out on the electrical protection system of the offsite 400 kV switchyard, the unit breaker opened. The cause was incorrect wiring of one channel of the protection system. The opening of the unit breaker resulted in a load rejection to house load. All required automatic actions were started properly.

### Important to Availability

**April 27:** Coast-down operation was initiated. The power level at the end of the cycle was 85%.

The date for refueling shut-down was postponed by one week. Coast-down operation corresponded to a production loss of about four equivalent full power days.

#### Refueling outage, June 13 to July 7:

The refueling outage was scheduled to last 23 days, but was extended to 24 days.

In addition to general preventive maintenance and inspection work, the following major work was performed:

- Pressure test of the primary system. Due to a minor leakage, the pressure test had to be repeated, which caused the extension of the refueling outage.
- Ultrasonic testing of the reactor vessel.
- Sipping of all unloaded fuel elements. One leaker was detected.
- Inspection of the main generator rotor.
- Replacement of the main generator voltage control system.
- Installation work for the third cooling system for the spent fuel pool.
- Loading of 44 new fuel elements. The newly-loaded fuel contains 20 Mox fuel elements.

# History

# Characteristics

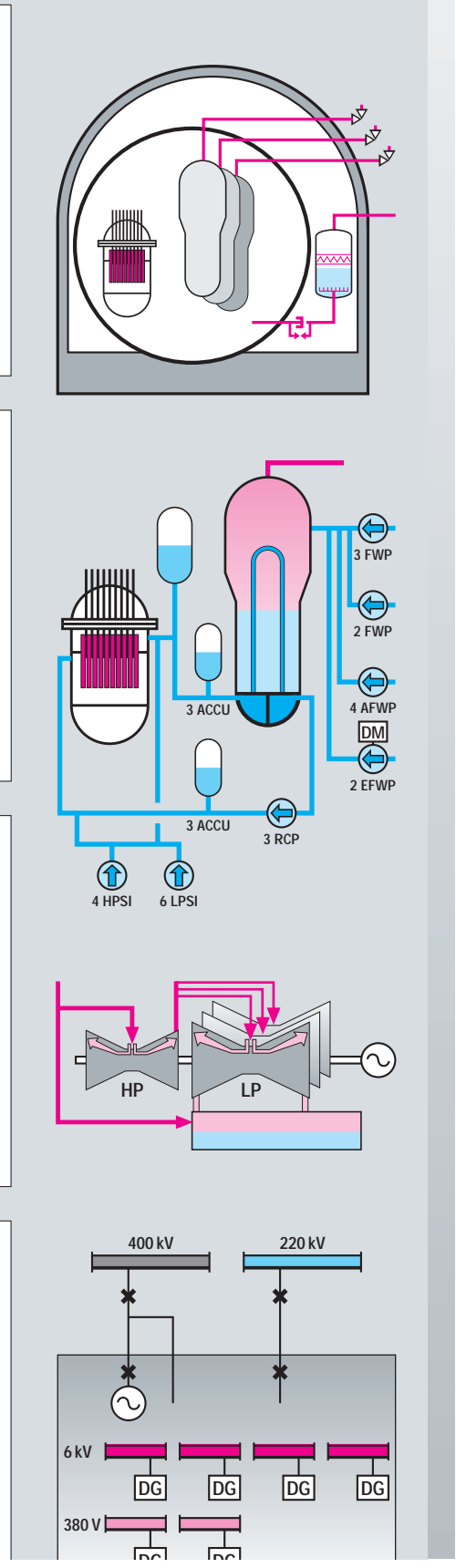
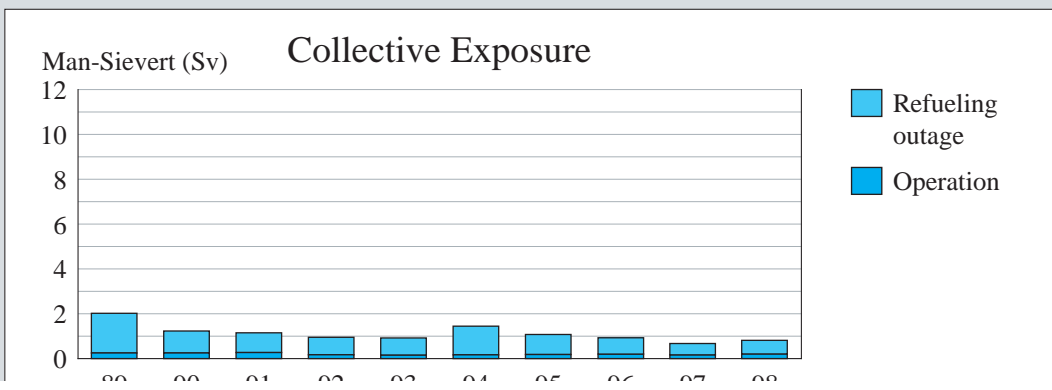
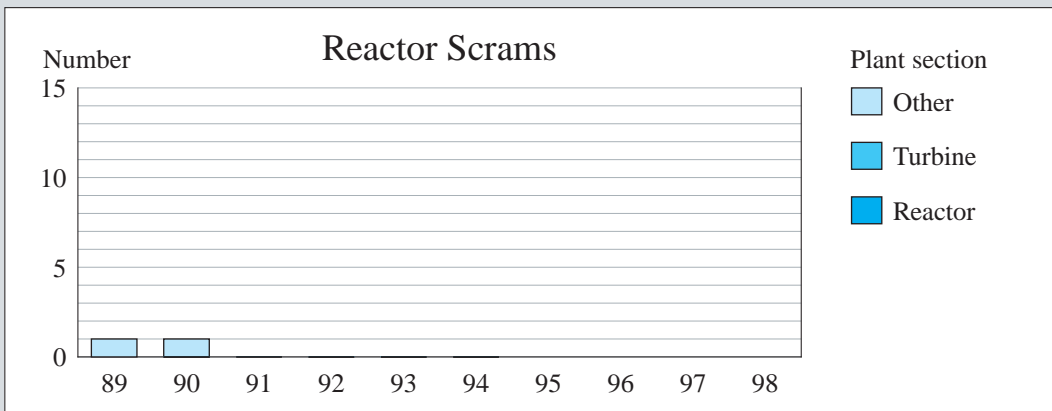
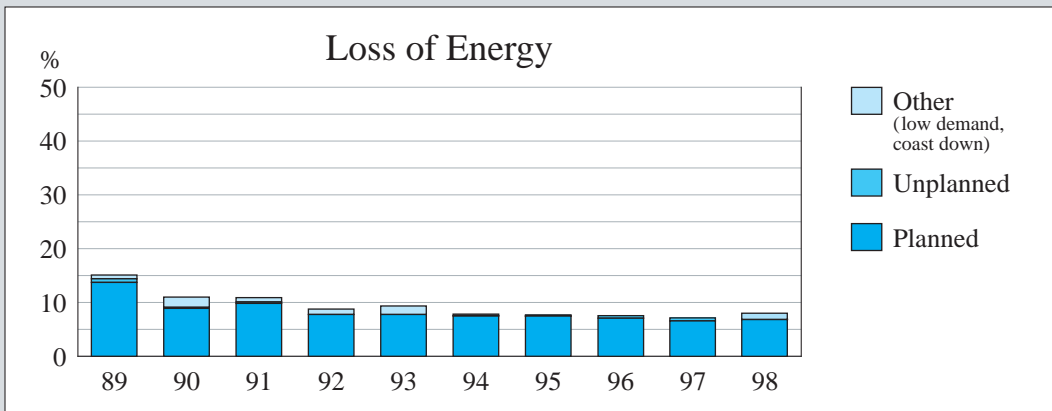
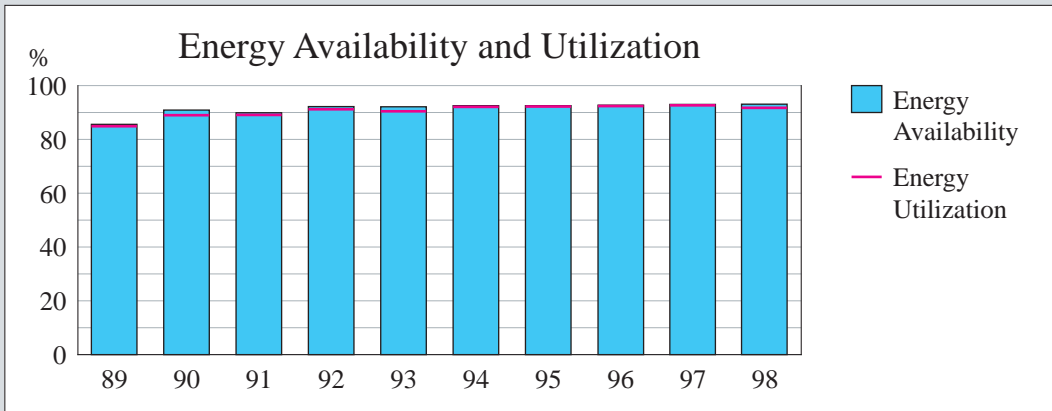

# Leibstadt

## Operating Experience 1998

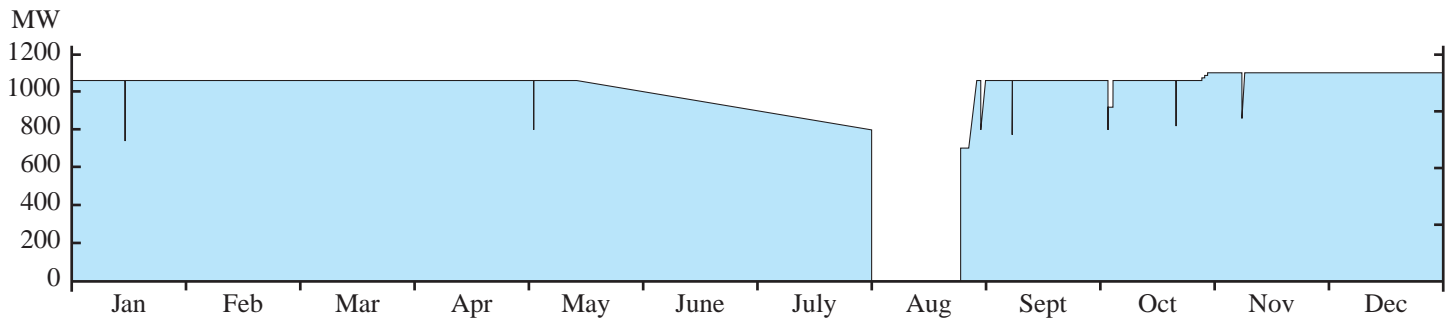

### Important to Safety

#### Scrams:

There were no automatic scrams during power operation.

### Important to Availability

**Jan 17:** Planned load reduction for control rod pattern adjustment and MSIV full / fast closure surveillance.

**May 2:** Planned load reduction for MSIV full / fast closure surveillance.

**May 14:** Began end-of-cycle coast-down.

#### **July 31 – Aug 26: 14th Refueling Outage**

The outage duration was 25.8 days (scheduled: 26.0 days). 112 new (out of 648) fuel bundles were loaded.

**Aug 26:** Planned generator load reject test from 25% rated power.

**Aug 27:** Planned turbine trip test from 65% rated power.

**Aug 30:** Planned load reduction for control rod pattern adjustment and MSIV full / fast closure surveillance.

**Sep 11:** Unplanned load reduction due to a reactor recirculation system runback during performance of a surveillance on the bypass valves.

**Oct 3:** Planned load reduction for control rod pattern adjustment and inspection of main circuit water system piping (VC41).

**Oct 24:** Planned load reduction for control rod pattern adjustment and MSIV full / fast closure surveillance.

**Oct 29:** Increased reactor power to 102% for implementation of power uprating.

**Oct 30:** Increased reactor power to 104% for implementation of power uprating.

**Oct 31:** Increased reactor power to 106% for implementation of power uprating.

**Nov 11:** Planned load reduction for control rod pattern adjustment.

# History

# Characteristics

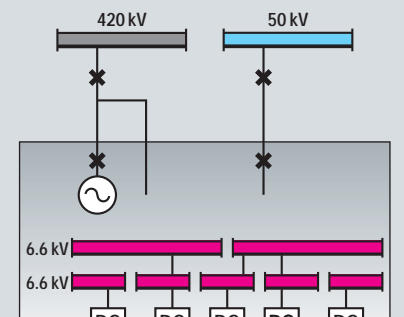
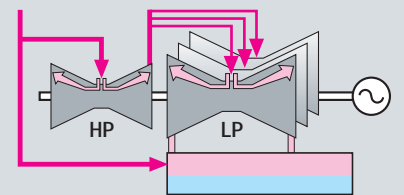
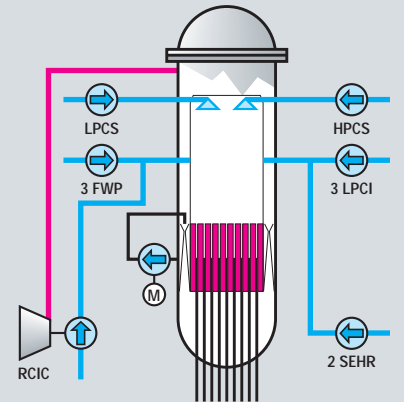
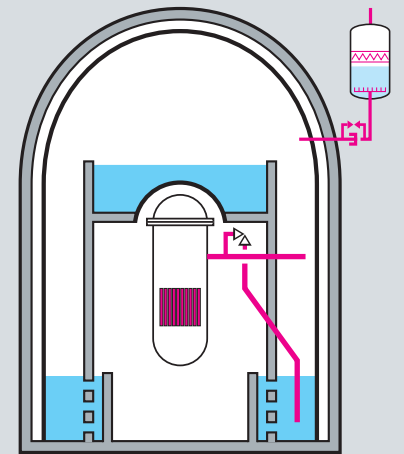
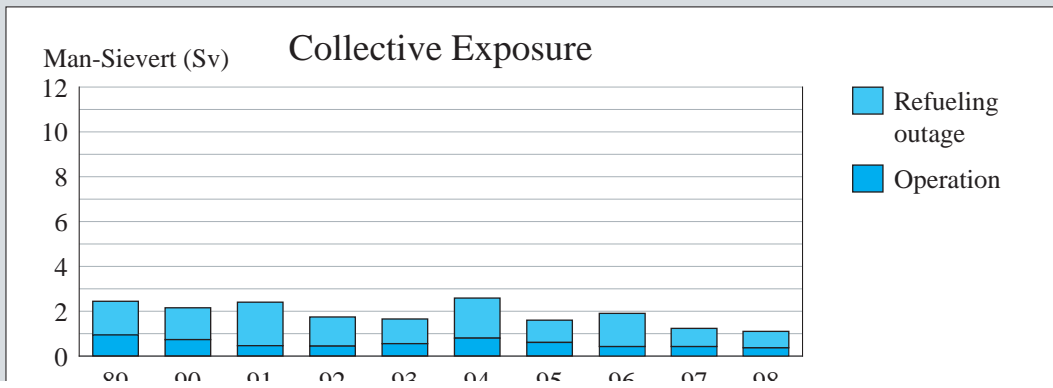
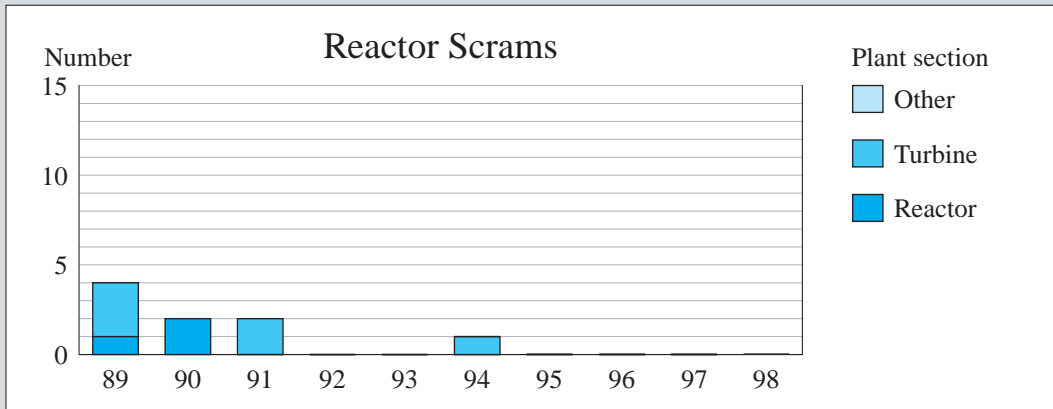
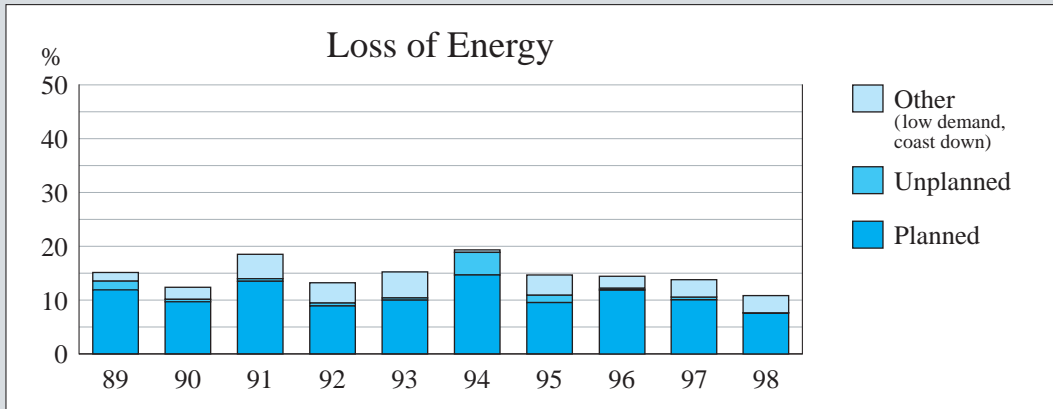
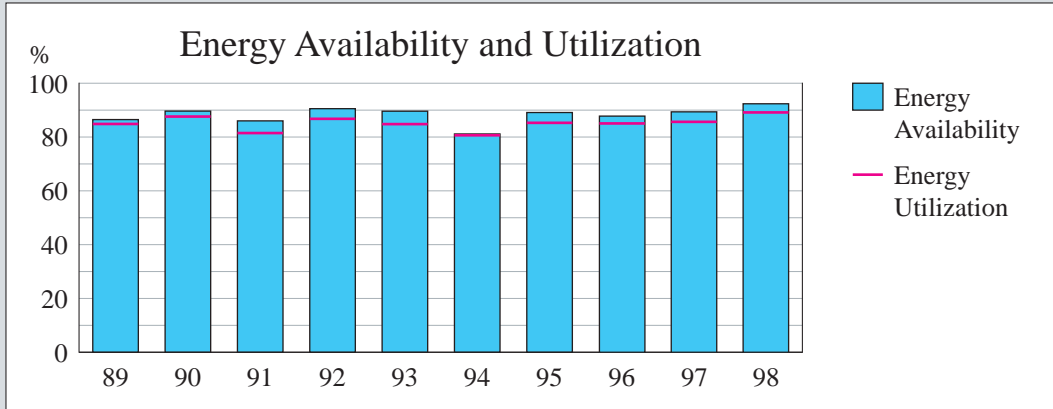

The first two Swiss nuclear power plants, Beznau and Mühleberg, each belong to a single large public electric utility, whereas the two later plants, Gösgen and Leibstadt, are partner plants of several electric utilities and public service companies. The concept of partner nuclear power plants made it possible, when they were set up in the seventies, for medium-sized and smaller organisations to share in economically attractive, large-scale power generation plants and to gain access to the latest technology. In each case one of the partners has responsibility for the business management on behalf of the others.

The Beznau nuclear power plant is fully owned by its operator, Nordostschweizerische Kraftwerke.

Likewise, the Mühleberg nuclear power plant belongs fully to BKW FMB Energie AG.

The partners of Kernkraftwerk Gösgen-Däniken AG (KKG) are:

- Aare-Tessin AG für Elektrizität (ATEL, 35%, managing partner)
- Nordostschweizerische Kraftwerke (NOK, 25%)
- the City of Zurich (15%)
- Centralschweizerische Kraftwerke (CKW, 12.5%)
- the City of Berne (7.5%)
- Swiss Federal Railways (SBB, 5%)

Kernkraftwerk Leibstadt AG (KKL) is owned by the following partners:

- Elektrizitäts-Gesellschaft Laufenburg AG (EGL, 15%, managing partner)
- Aare-Tessin AG für Elektrizität (ATEL, 21.5%)
- Aargauisches Elektrizitätswerk (AEW, 5%)
- Badenwerk AG (BW, 7.5%)
- BKW FMB Energie AG Beteiligungsgesellschaft (BKW/BG, 7.5%)
- Centralschweizerische Kraftwerke (CKW, 12.5%)
- Kraftübertragungswerke Rheinfelden (KWR, 5%)
- Kraftwerk Laufenburg (KWL, 7.5%)
- Nordostschweizerische Kraftwerke (NOK, 8.5%)
- S. A. l'Énergie de l'Ouest-Suisse (EOS, 5%)
- Swiss Federal Railways (SBB, 5%)

Copies of this report are available from:  
Swiss Association for Atomic Energy (SVA)  
P. O. Box 5032  
CH-3001 Berne  
Phone +41-31-320 65 25  
Telefax +41-31-320 68 31  
E-mail: sva@to.aey.ch  
<http://www.atomenergie.ch>



**Nordostschweizerische  
Kraftwerke  
Parkstrasse 23  
CH-5401 Baden  
Phone +41-56-200 31 11**



**BKW FMB Energie AG  
Viktoriaplatz 2  
CH-3000 Berne 25  
Phone +41-31-330 51 11**



**Kernkraftwerk  
Gösgen-Däniken AG  
CH-4658 Däniken  
Phone +41-62-288 20 00**



**Kernkraftwerk Leibstadt AG  
CH-5325 Leibstadt  
Phone +41-56-267 71 11**