

May 1998

Summary of  
**Operating Experience**  
in Swiss Nuclear Power Plants

1997

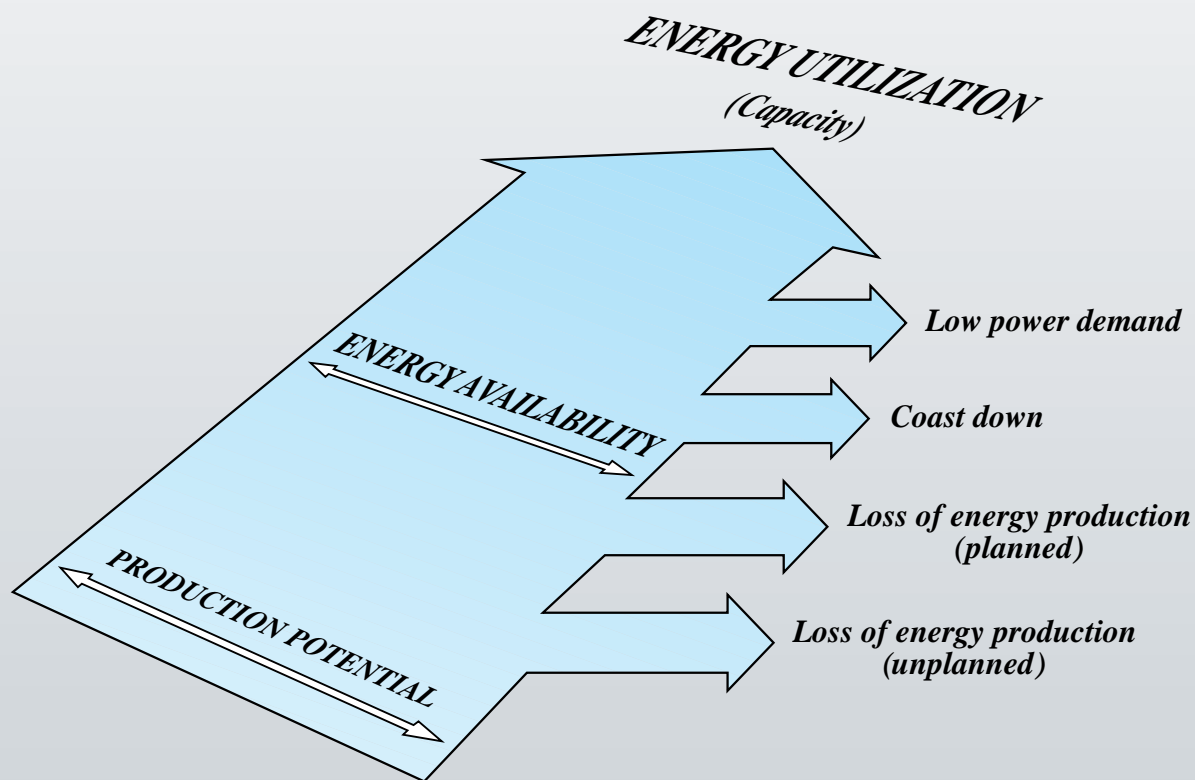



## SWISS NUCLEAR POWER PLANTS

Power station	Type of reactor	Net output (MWe)	Commercial operation
Beznau (KKB)	PWR	365	Unit 1: Dec. 24, 1969
		357	Unit 2: March 15, 1972
Mühleberg (KKM)	BWR	355	November 6, 1972
Gösgen (KKG)	PWR	970	November 19, 1979
Leibstadt (KKL)	BWR	1030	December 15, 1984

## DEFINITIONS

(Corresponding to the UNIPED classification «Statistical Terminology Employed in the Electrical Supply Industry»)

Energy availability factor –  $E_{tg}/E_n$   
(UNIPED definition 4.6.03.f)

Energy utilization factor –  $E_d/E_n$   
(UNIPED definition 4.5.01)

$E_n$  (Production Potential)

– energy producible assuming maximum capacity continuously available throughout a specific period

$E_d$  (Energy Utilization)

– energy actually produced within a specific period

$E_{tg}$  (Energy Availability)

– energy producible assuming available capacity during a specific period

In 1997, Switzerland's five nuclear power units achieved their highest-ever combined annual net output: 24,02 TWh. It was the first time that total net output topped the 24 TWh mark. The nuclear share in total electricity production was 39,6%. This was somewhat less than the previous year's share of 43%, but that figure was attributable largely to a drop in hydro production as a result of unusually dry weather conditions.

The excellent 1997 results were due to several factors:

- Once again, there were very few interruptions to plant operation.
- Over the past few years, a number of measures have been taken to improve plant performance. The results are now being seen.
- Refuelling and maintenance outages were short.

With regard to the last point, Gösigen's 1997 shut-down lasted just 23 days – once again a plant record. Outage periods for the other units were: Beznau-1, 43 days; Leibstadt, 35 days; Mühleberg, 44 days. Due to the 18-month cycle, there was no refuelling outage at Beznau-2.

Eight mixed oxide (MOX) fuel elements were loaded at Gösigen for the first time in 1997. MOX fuel has already been used for many years at Beznau.

Non-electrical energy delivery by at Beznau and Gösigen continued to function flawlessly. Beznau delivered 128 GWh of thermal energy to the Refuna district heating system, while Gösigen supplied 143 GWh of process heat to the nearby Niedergösigen cardboard factory.

An application for power uprating of the Leibstadt reactor is still pending, as is an application to lift the restriction preventing Mühleberg operating beyond the year 2002 with its current licence.

Swiss Association for Atomic Energy (SVA)

*Hans Jörg Huber*

Dr Hans Jörg Huber, President

*Hählen*

Dr Peter Hählen, Secretary General

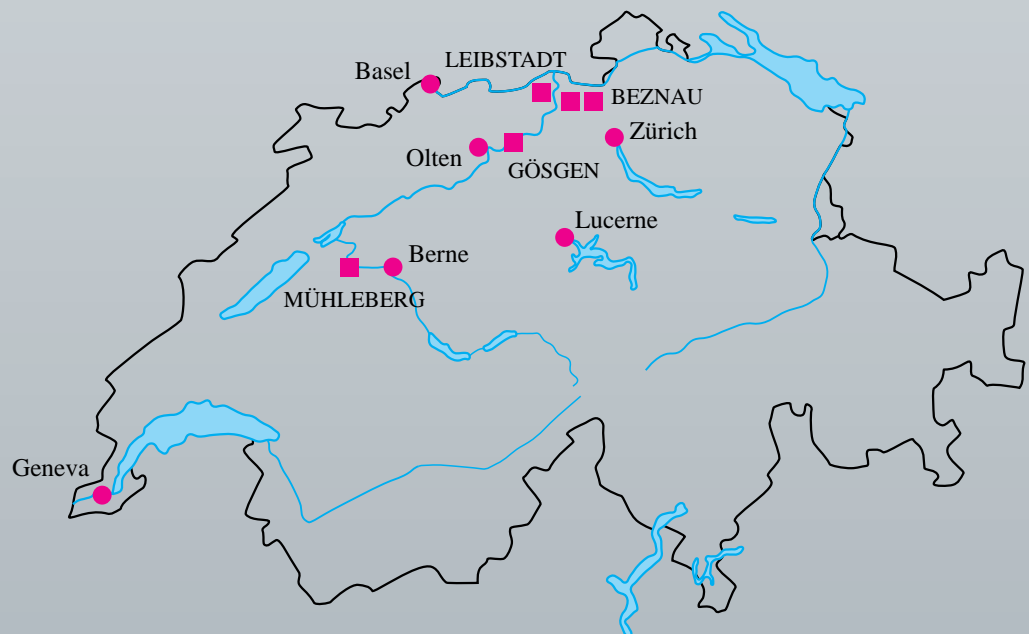

# Swiss Nuclear Power Plants: Production Figures 1997 and History

	Gross production MWh	Net production MWh	Total operating time (power production) h	Total gross production since start of operation MWh	Total net production since start of operation MWh
KKB 1	2 829 207	2 708 211	7731	71 917 947	68 762 811
KKB 2	3 221 448	3 090 236	8737	72 345 390	69 300 841
KKM	2 658 446	2 549 153	7671	64 599 293	61 636 212
KKG	8 360 354	7 907 783	8205	138 863 420	130 945 156
KKL	8 192 680	7 762 496	7866.5	103 102 444	97 531 162

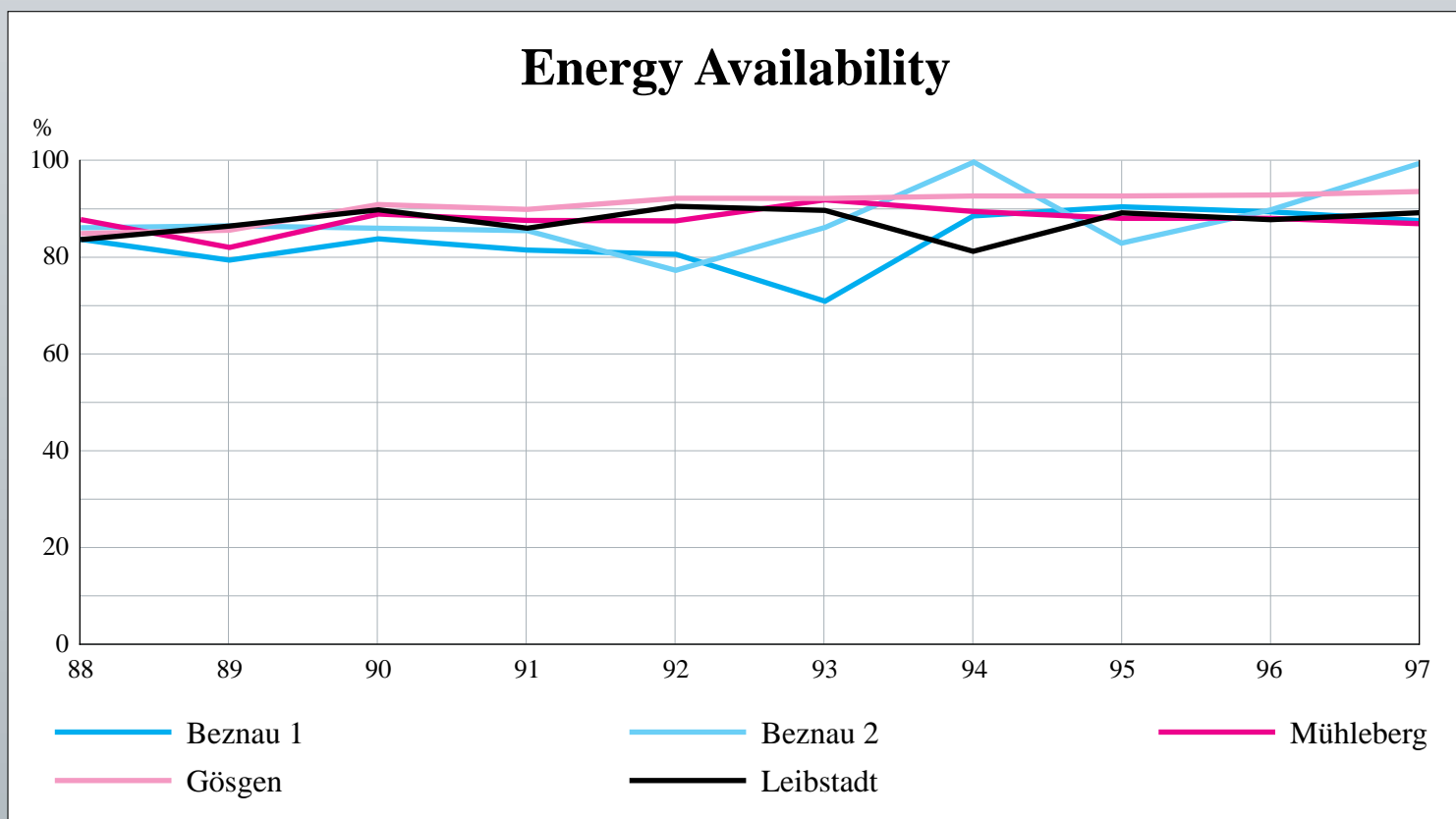

## Collective Exposure

Man-Sievert (Sv)

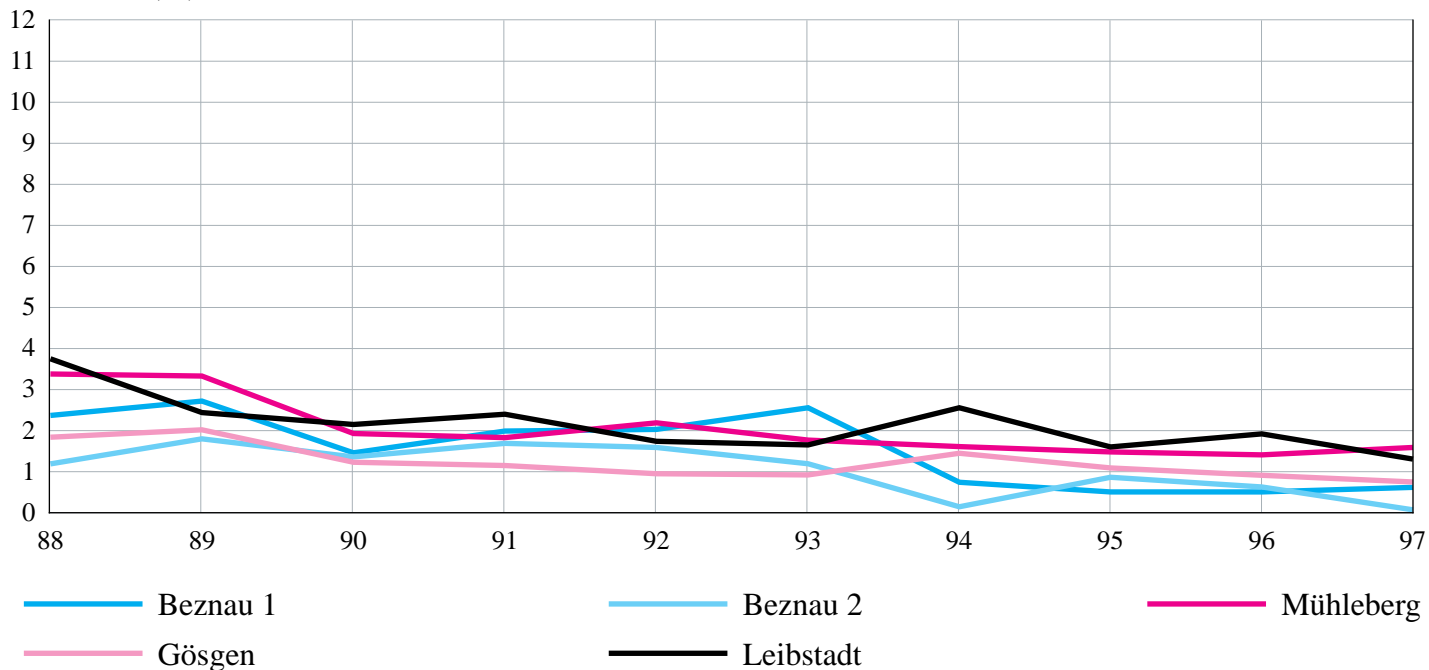

## Reactor Scrams

Number

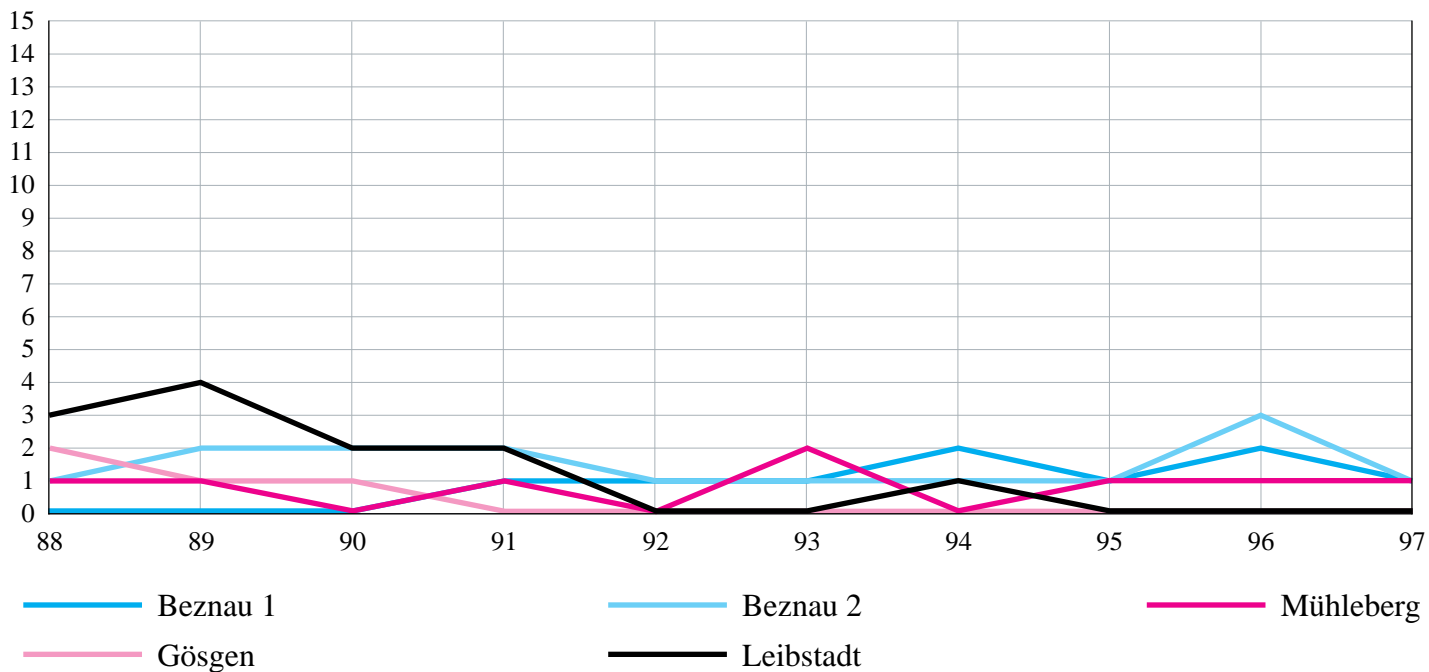

# Beznau 1

## Operating Experience 1997

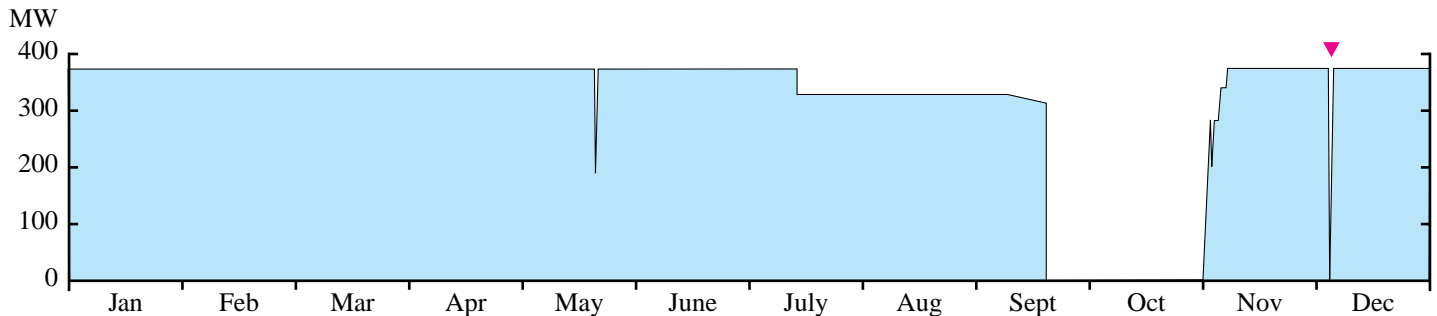

### Important to Safety

#### Scrams:

▼ **December 3:** Humidity accumulating on a terminal block of an instrumentation cable outside the turbine building caused the opening of the line-breaker and thus activated a scram.

#### Other:

During the refueling outage, an extended inspection program was carried out involving the reactor vessel, the primary system and the steam generators. The results demonstrate that all inspected systems and components are in good condition. The sipping test of the fuel elements revealed leaks on three MOX elements. These have been replaced. Soon after the refueling outage, a hand operated valve in one of three trains of the emergency core cooling system was found to be in the wrong position. Action was taken immediately to prevent similar occurrences during future outages.

### Important to Availability

**May 21:** Load reduction to 50% power due to maintenance work on a turbine steam reheater.

**July 11:** 10% load reduction followed by a coast down due to core reactivity reduction. By the time the plant shut-down on September 19th, for the refueling outage, the power level had decreased to 85%.

#### Main outage activities:

- Replacement of 44 fuel elements.
- In service inspection of reactor vessel and head, primary cooling system and steam generator tubing.
- Improvements on a high pressure turbine.
- Replacement of the auxiliary transformers and the generator exciter systems.

# History

# Characteristics

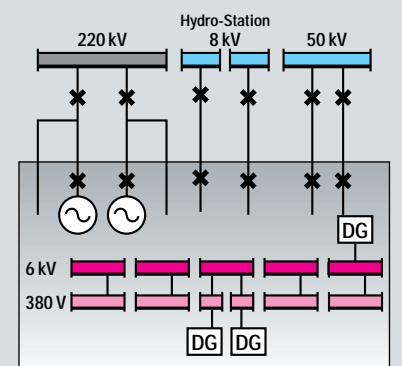
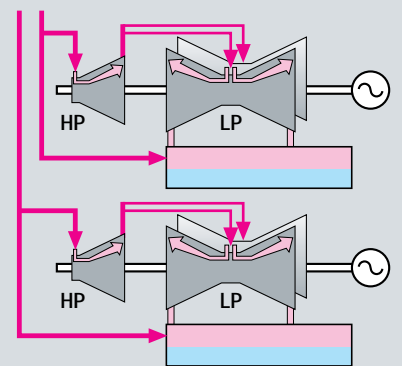
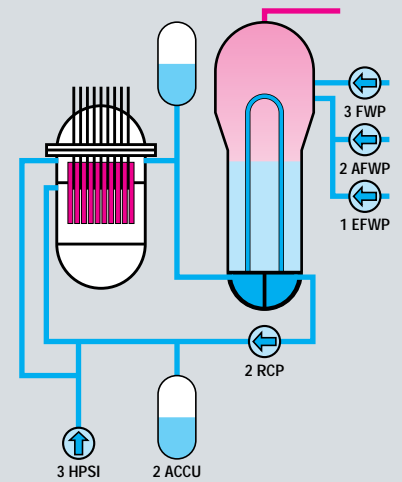
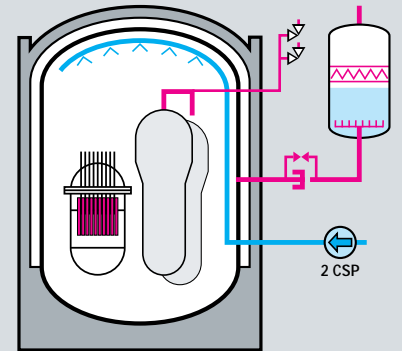
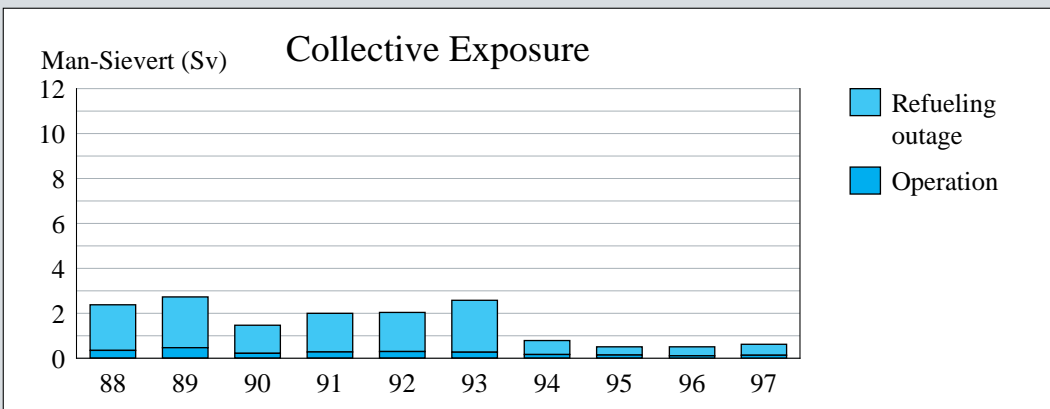
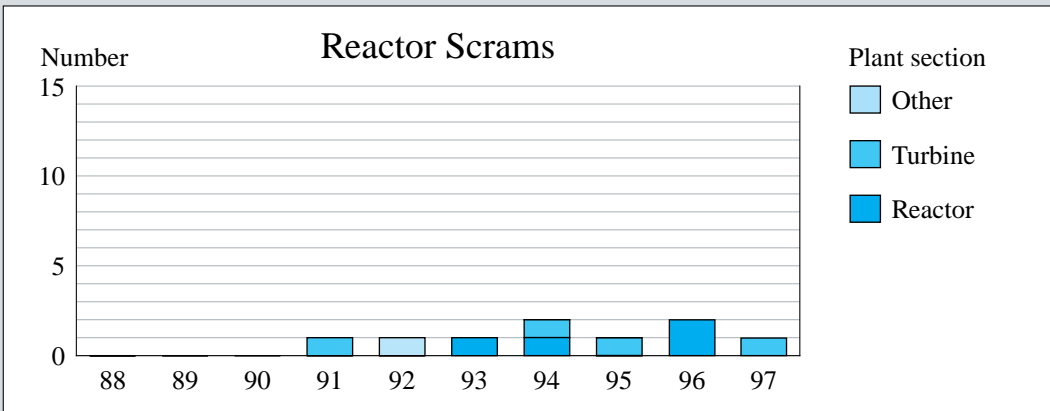
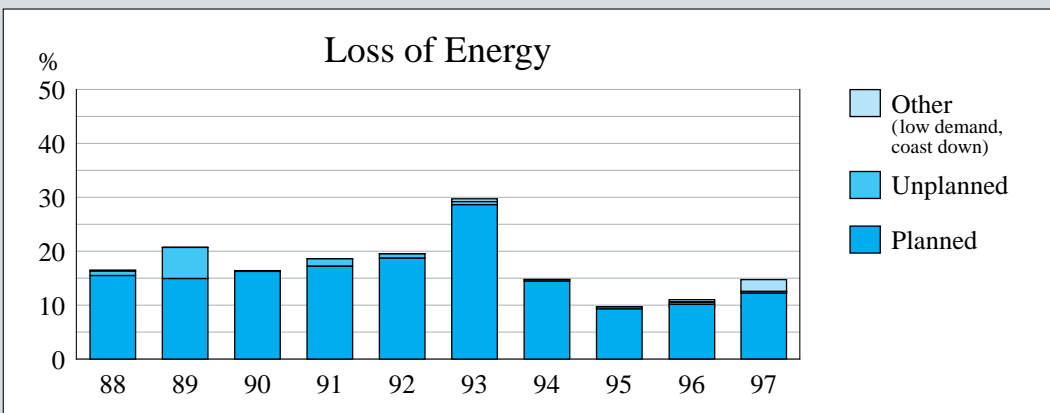
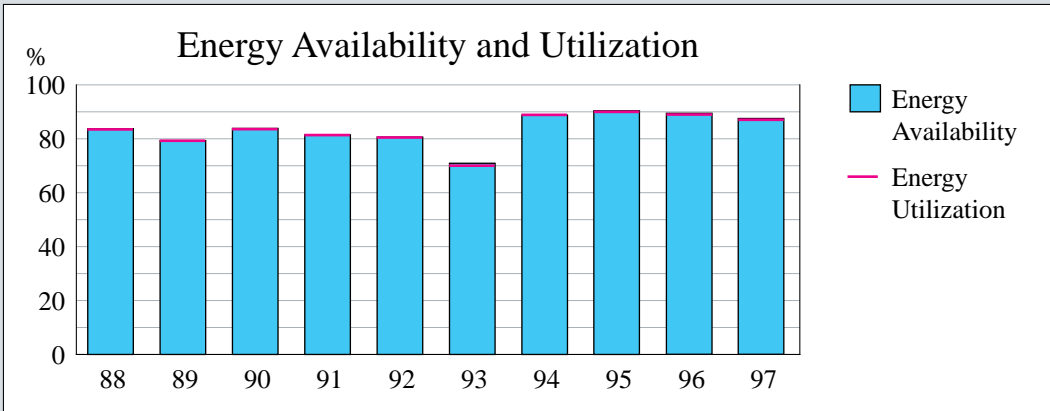

# Beznau 2

## Operating Experience 1997

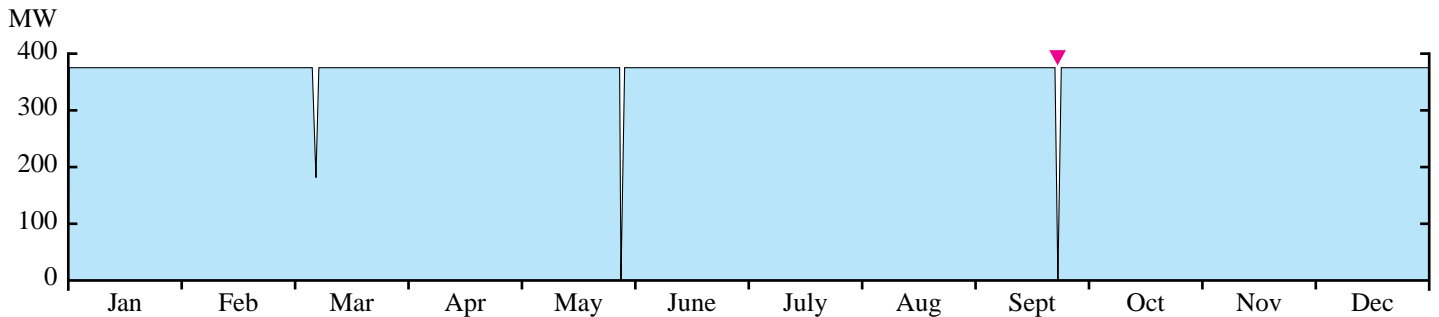

### Important to Safety

#### Scrams:

▼ **September 24:** The stop of a feedwater pump was activated during replacement of the level switch on a feedwater tank. The decreasing level in the steam generators and the mismatch in the steam/feedwater flow subsequently caused a scram.

#### Other:

**May 24:** The aim of the planned shut-down of about one day was to implement a new wide-range neutron detector. The following test phase demonstrated the expected behaviour of the detector as a part of the new future neutron flux measuring equipment.

### Important to Availability

**March 6:** Load reduction to 50% power due to inadvertent switching-off of the exciter on one turbine.

No refueling at Beznau 2. The next refueling outage is planned for April / May 1998 (18-month cycle).

# History

# Characteristics

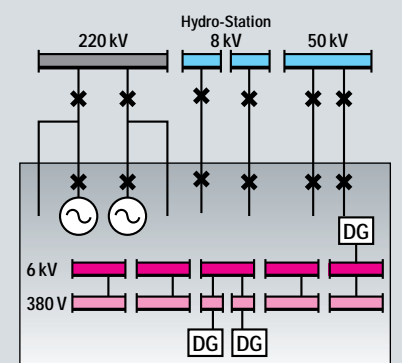
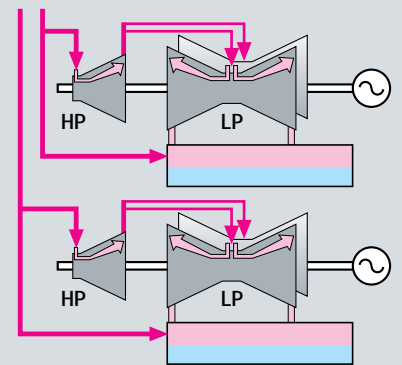
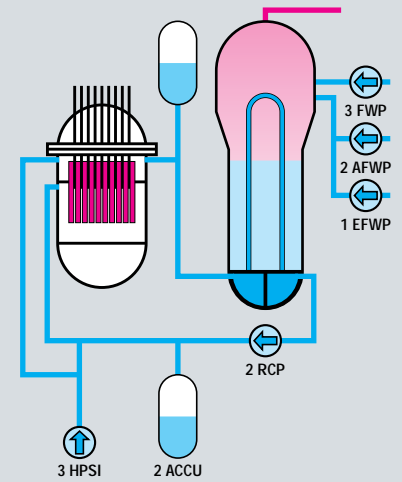
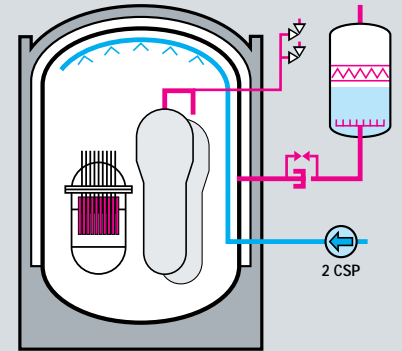
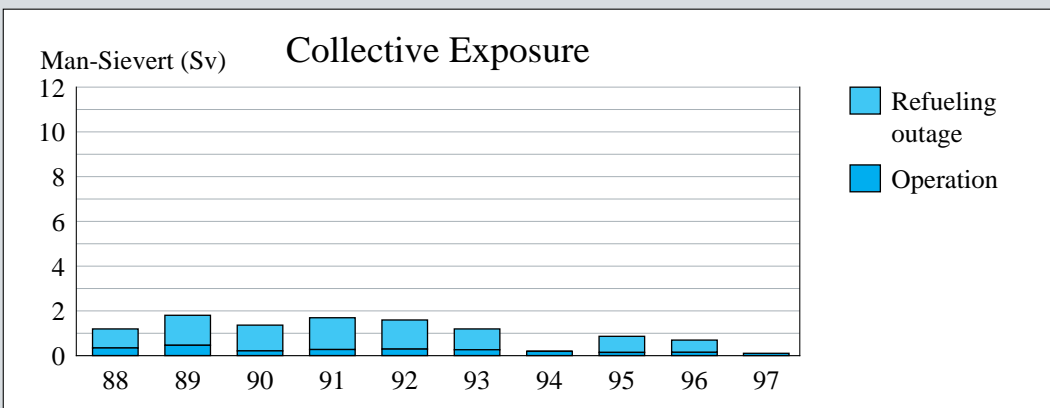
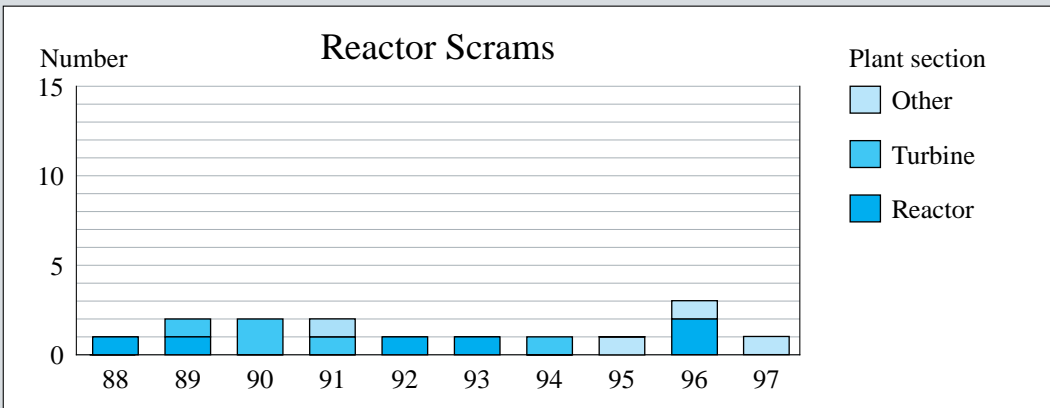
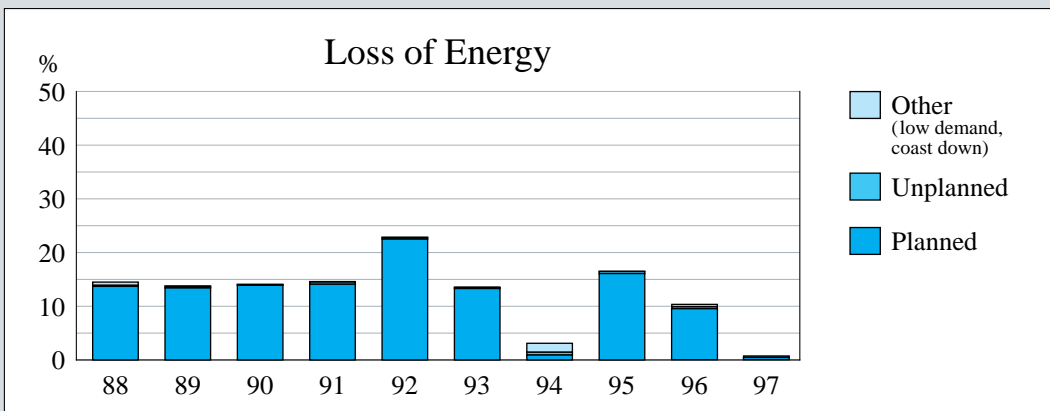
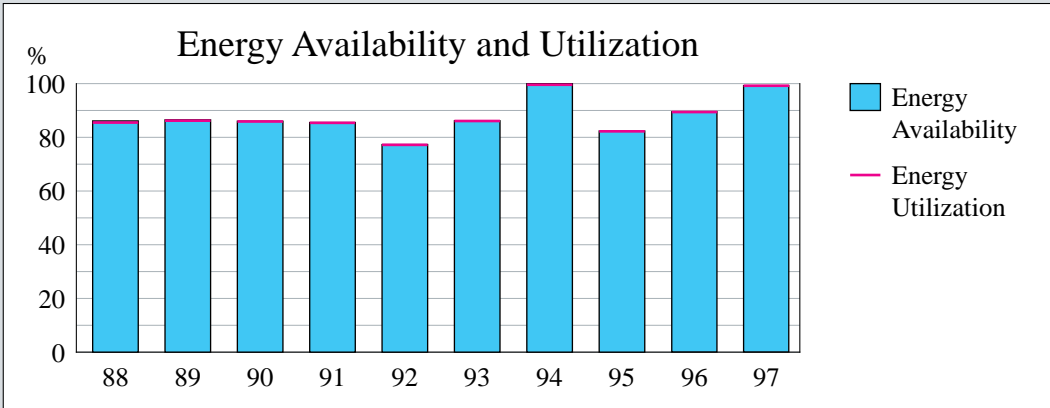

# Mühleberg

## Operating Experience 1997

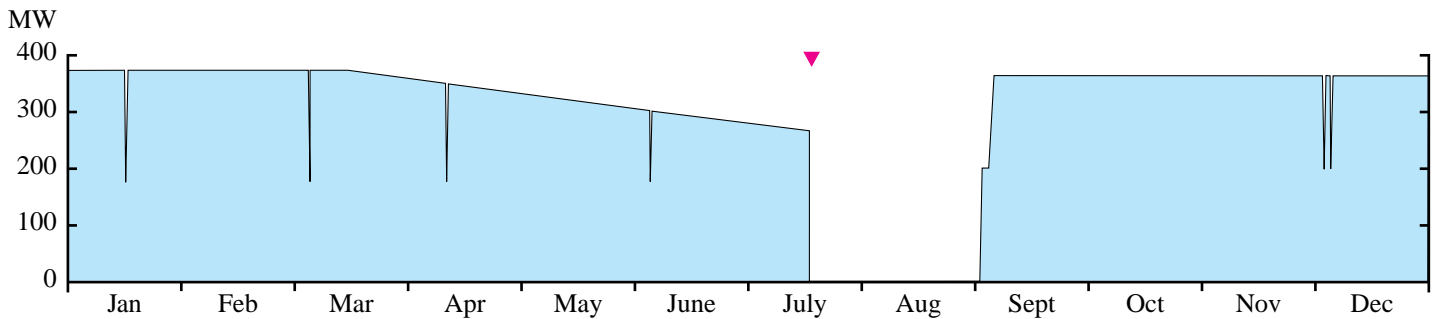

### Important to safety

#### Scrams:

▼ **July 19:** Problems in the electronic control of the thyristor in the generator B excitation field caused a load reject followed by a select rod insert and a recirculation pump runback. Due to a failure of a control element, the feedwater control system was not able to control the feedwater flow quickly enough and the water level in the reactor vessel reached the low level scram point.

#### Others:

Severe damage of an emergency diesel power unit occurred during a periodic test. The engine was replaced by an identical spare diesel unit within the technical specifications repair time; the plant was thus able to remain connected to the grid. The damaged diesel was shipped to the factory for a root cause analysis of the damage and a complete overhaul.

### Important to availability

**March 9:** The planned coast-down operation began. The power level at the end of the cycle was 69%.

#### Refueling outage, July 21 – September 2

The planned outage lasted 44 days. After the scram on 19 July, management decided, due to low load demand, to keep the plant shut down, although this was 36 hours ahead of schedule. All control rod drive units were overhauled and tested. The four feedwater nozzles were modified with a new thermal sleeve design. The two low pressure stages of one turbine were completely overhauled. At the end of the shutdown a pressure test of the primary system at 103 bars was successfully performed. 44 of the 240 fuel elements were replaced by new ones.

#### Load reductions:

A total of 6 load reductions (> one full power hour) were required. One was to repair a cooling water leak in the condenser of turbine B, one was to change brushes of the MG-Set A motor and one was due to a plugged drain at an offgas condenser. Three load reductions to 50% were required for surveillance tests.

# History

# Characteristics

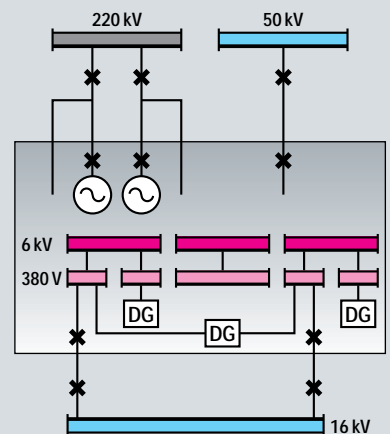
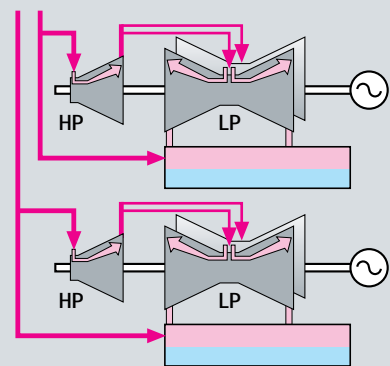
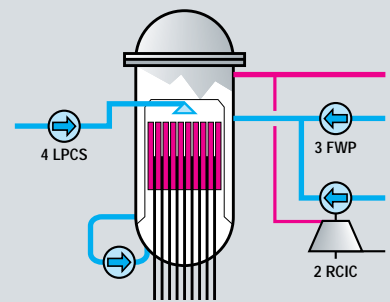
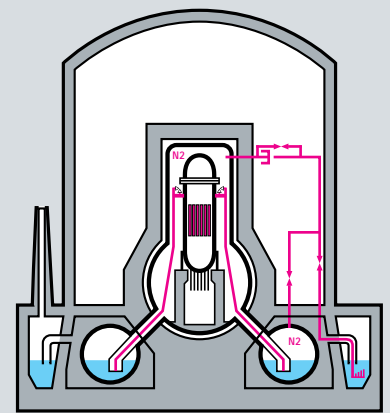
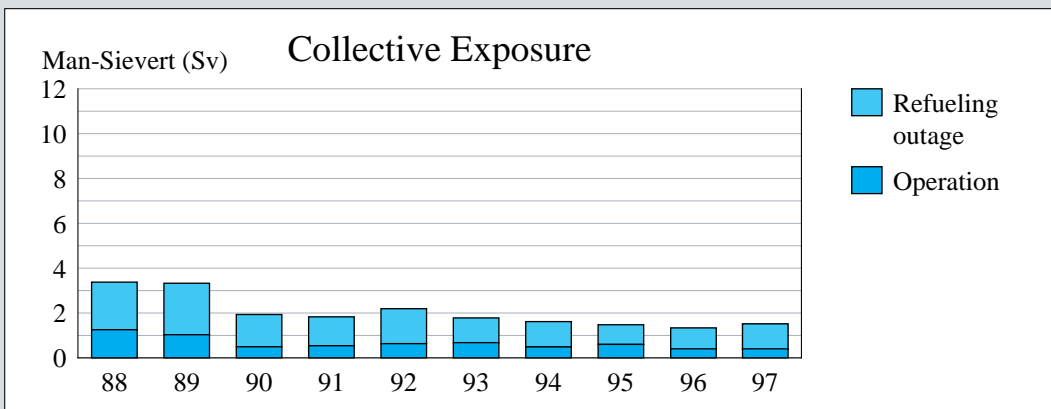
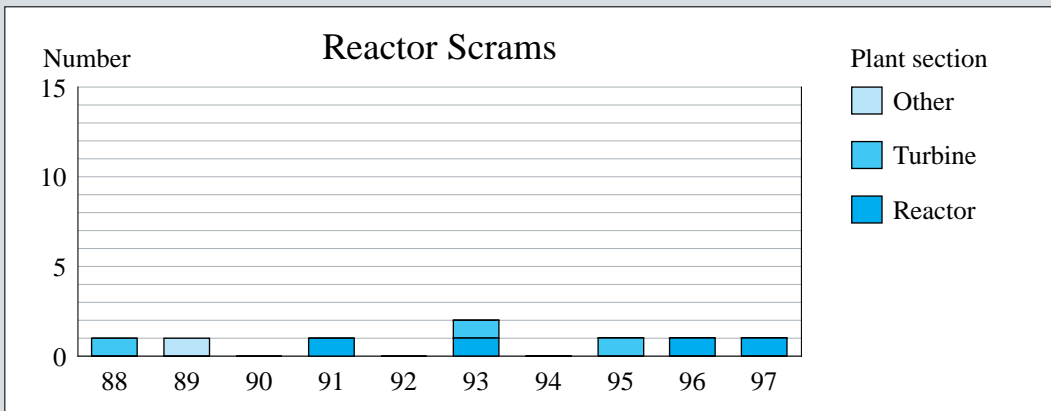
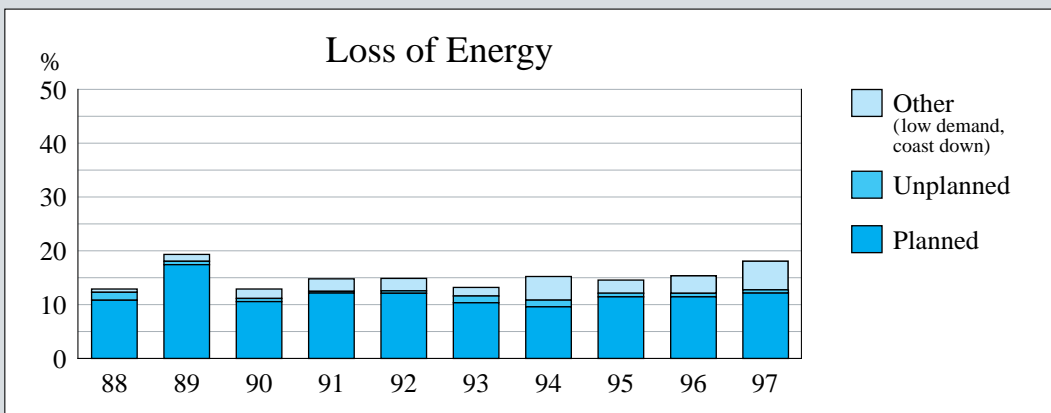
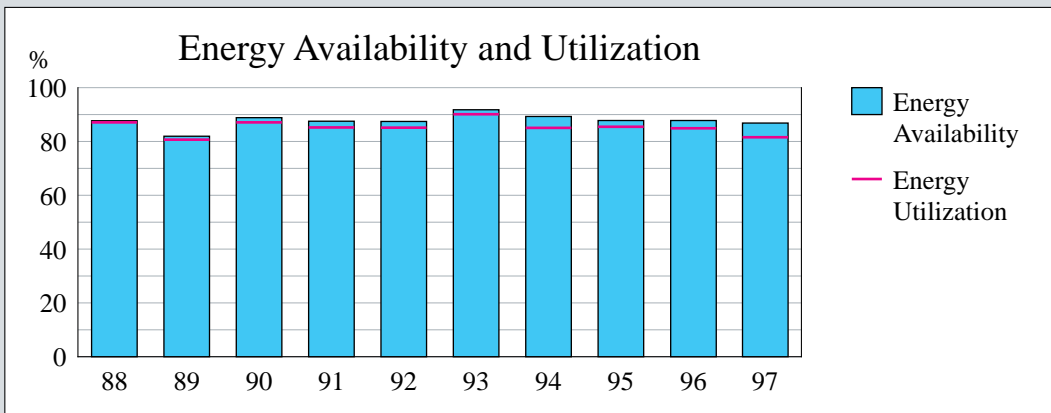

# Gösgen

## Operating Experience 1997

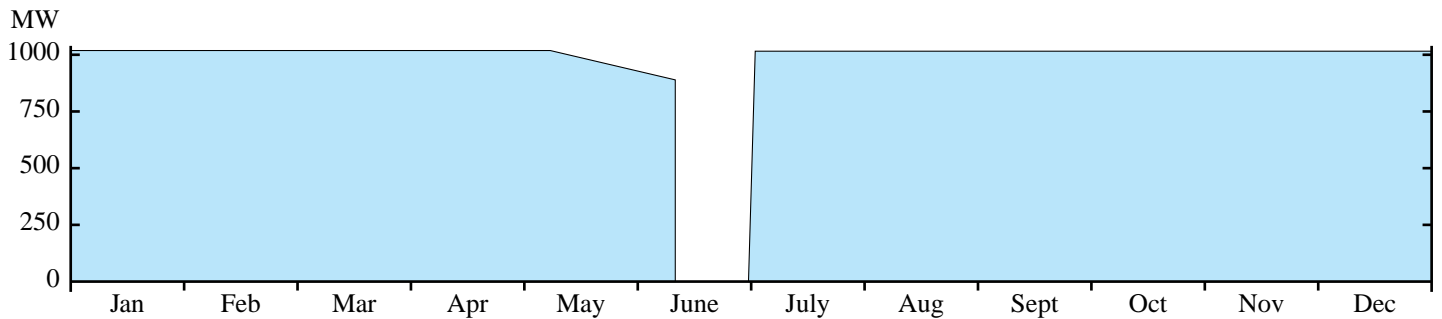

### Important to Safety

1997 was the seventh consecutive year of operation without any unplanned scrams.

### Important to Availability

In 1997, there was no unplanned loss of energy.

**May 7:** Start of coast-down operation. When the plant was shut down for refueling on June 7, the power level was decreased to 86%.

#### **Refueling outage, June 7 – June 30:**

The refueling outage was carried out according to schedule. This was the shortest outage in the history of the unit, lasting 23 days.

In addition to general preventive maintenance and inspection work, the following major work was performed:

- Leak rate test of the steel containment.
- Sipping of all unloaded fuel elements. Two leaking fuel elements were detected.
- Loading of 40 new fuel elements. The new loaded fuel contains 8 MOX fuel elements.

# History

# Characteristics

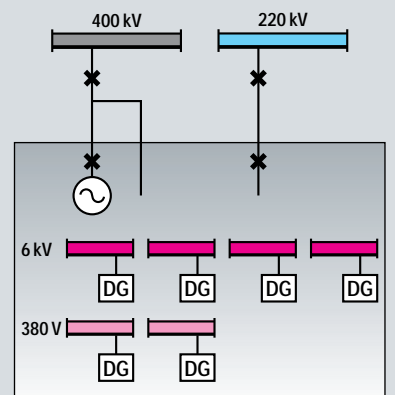
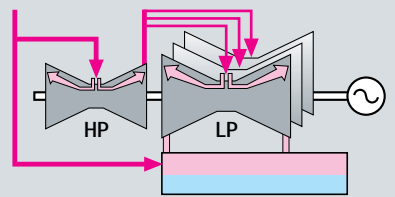
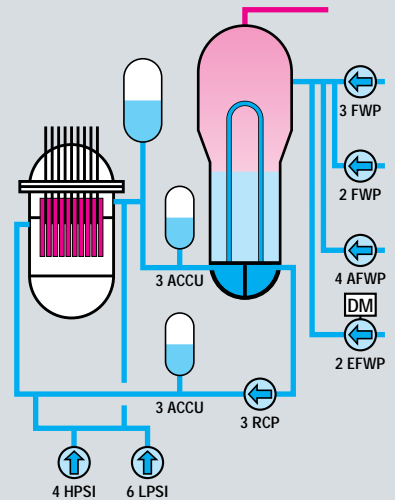
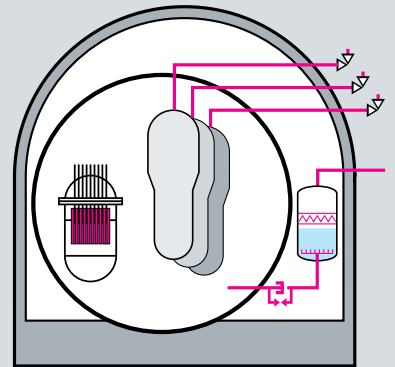
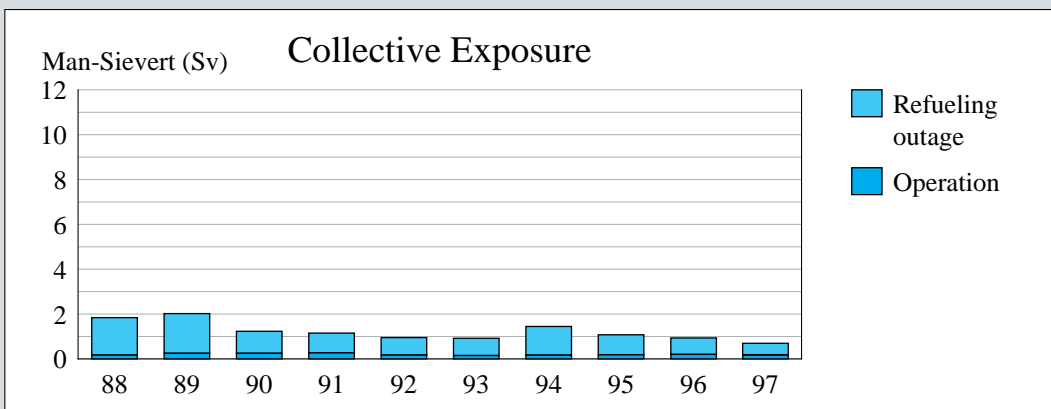
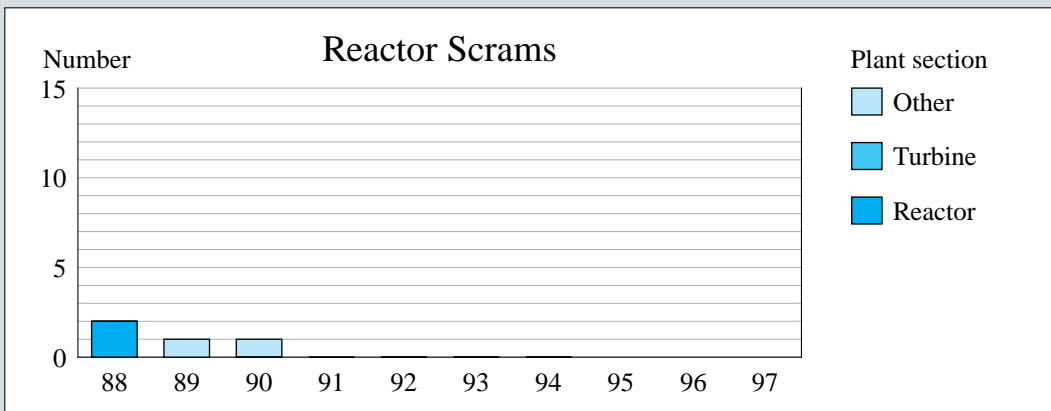
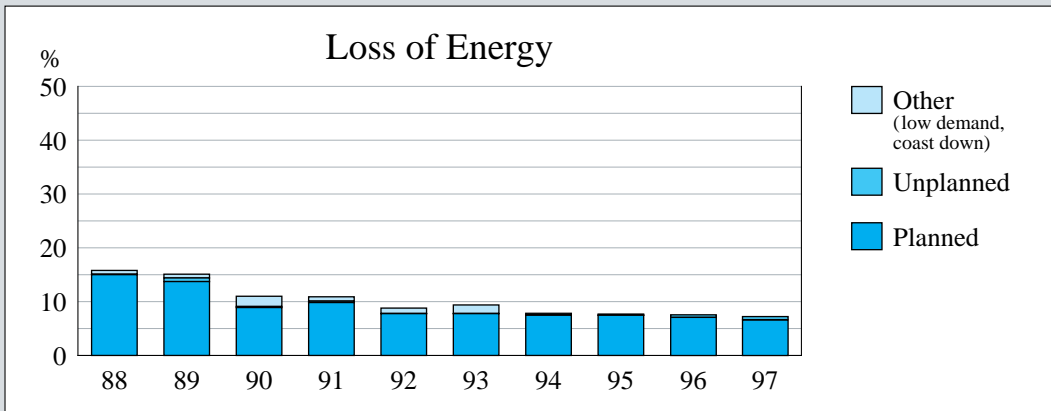
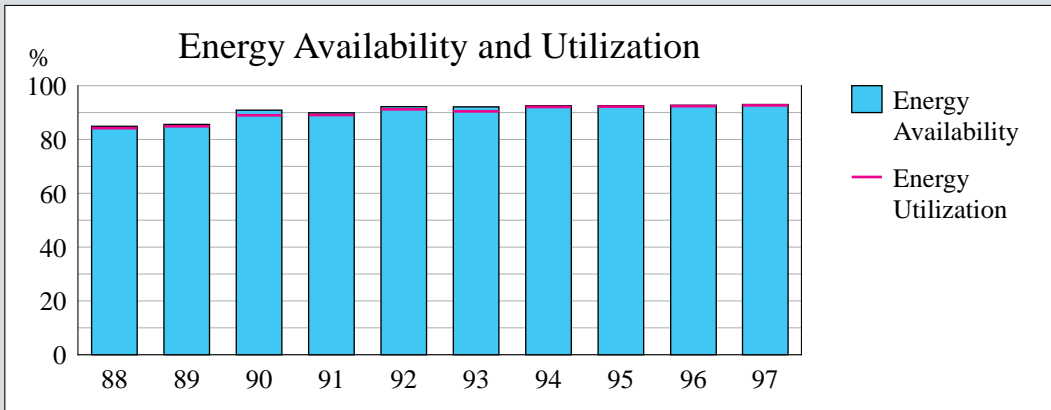

# Leibstadt

## Operating Experience 1997

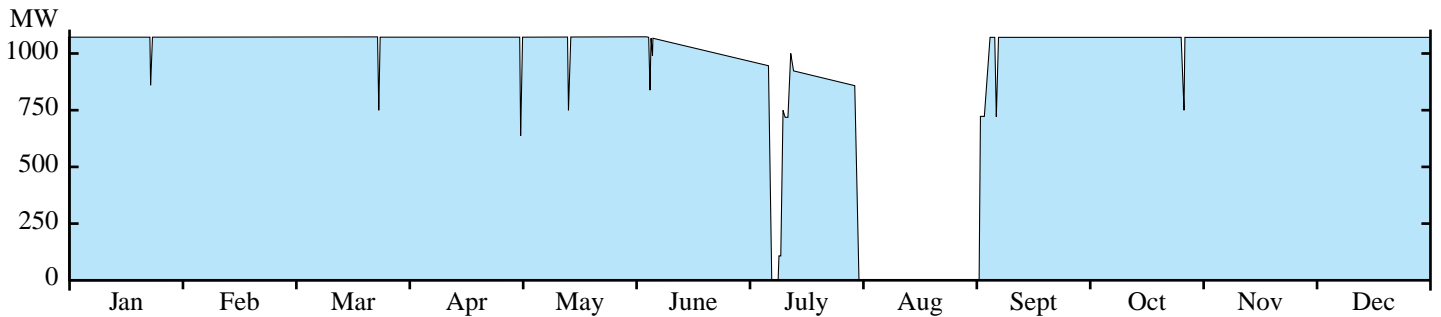

### Important to Safety

#### Scrams:

There were no automatic scrams during power operation.

### Important to Availability

**Jan 25:** Planned load reduction for main steam isolation valve MSIV full/fast closure quarterly surveillance.

**March 22:** Planned load reduction for control rod pattern adjustment.

**April 30:** Unplanned load reductions due to reactor recirculation system runback.

**May 17:** Planned load reduction for MSIV full/fast closure quarterly surveillance and control rod pattern adjustment (ARO).

**June 2:** Started expected end-of-cycle coast-down.

**June 3:** Planned load reduction for installation of a seal over a flange leak.

**July 4:** Main turbine automatic trip at 91% reactor power due to no. 3 bearing high temperature signal initiated by electronic card failure in the turbine bearing temperature monitoring system.

**Sept 5:** Planned load reduction for control rod pattern adjustment.

#### Refueling Outage, July 28 – September 1:

The 13th refueling outage duration lasted 35.4 days, as scheduled. 296 out of 648 fuel bundles were replaced, including 184 previously discharged bundles which were reinserted into the core.

**Oct 25:** Planned load reduction for MSIV full/fast closure quarterly surveillance and for control rod pattern adjustment.

# History

# Characteristics

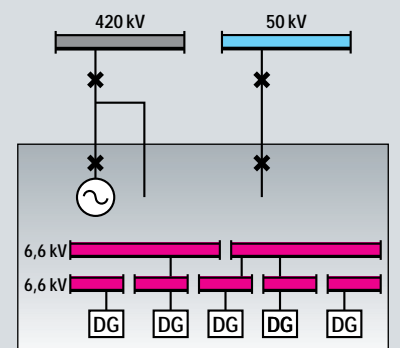
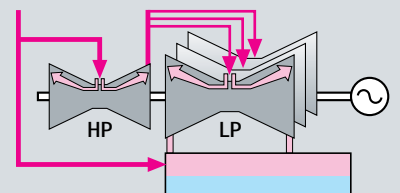
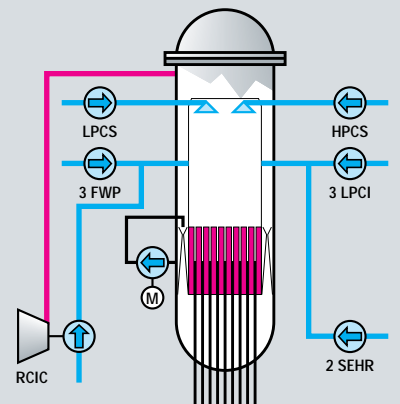
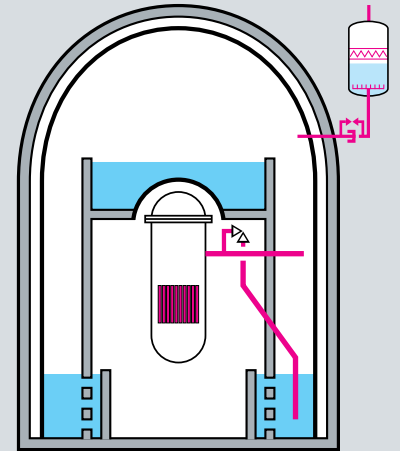
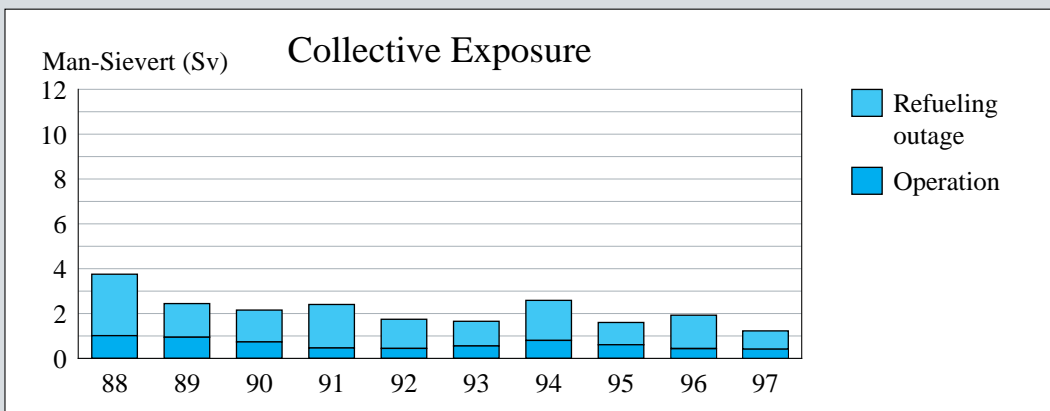
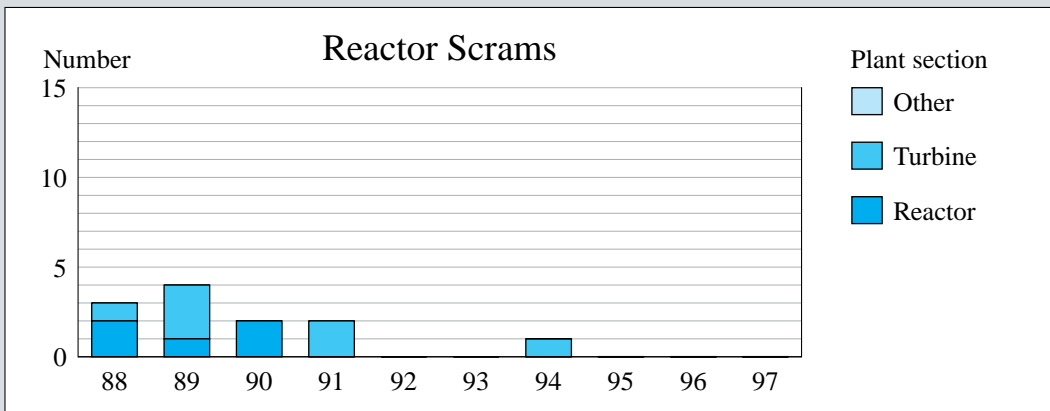
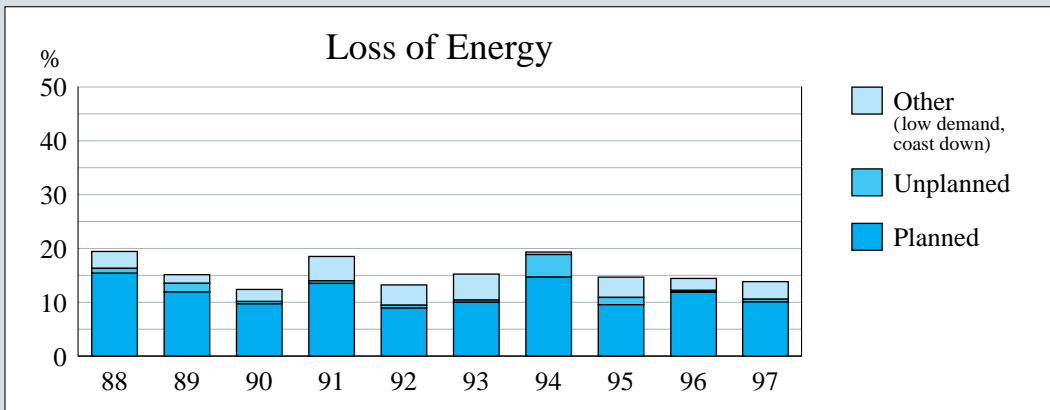
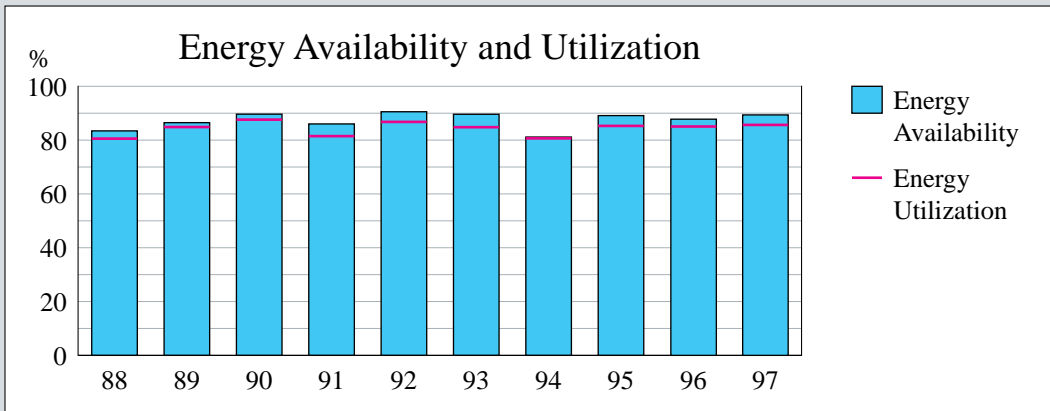

The first two Swiss nuclear power plants, Beznau and Mühleberg, each belong to a single large public electric utility, whereas the two later plants, Gösgen and Leibstadt, are partner plants of several electric utilities and public service companies. The concept of partner nuclear power plants made it possible, when they were set up in the seventies, for medium-sized and smaller organisations to share in economically attractive, large-scale power generation plants and to gain access to the latest technology. In each case one of the partners has responsibility for the business management on behalf of the others.

The Beznau nuclear power plant is fully owned by its operator, Nordostschweizerische Kraftwerke.

Likewise, the Mühleberg nuclear power plant belongs fully to BKW FMB Energie AG.

The partners of Kernkraftwerk Gösgen-Däniken AG (KKG) are:

- Aare-Tessin AG für Elektrizität (ATEL, 35%, managing partner)
- Nordostschweizerische Kraftwerke (NOK, 25%)
- the City of Zurich (15%)
- Centralschweizerische Kraftwerke (CKW, 12.5%)
- the City of Berne (7.5%)
- Swiss Federal Railways (SBB, 5%)

Kernkraftwerk Leibstadt AG (KKL) is owned by the following partners:

- Elektrizitäts-Gesellschaft Laufenburg AG (EGL, 15%, managing partner)
- Aare-Tessin AG für Elektrizität (ATEL, 21.5%)
- Aargauisches Elektrizitätswerk (AEW, 5%)
- Badenwerk AG (BW, 7.5%)
- BKW FMB Energie AG Beteiligungsgesellschaft (BKW/BG, 7.5%)
- Centralschweizerische Kraftwerke (CKW, 12.5%)
- Kraftübertragungswerke Rheinfelden (KWR, 5%)
- Kraftwerk Laufenburg (KWL, 7.5%)
- Nordostschweizerische Kraftwerke (NOK, 8.5%)
- S.A. l'Energie de l'Ouest-Suisse (EOS, 5%)
- Swiss Federal Railways (SBB, 5%)

Copies of this report are available from:  
Swiss Association for Atomic Energy (SVA)  
P. O. Box 5032  
CH-3001 Berne  
Phone +41-31-311 58 82  
Telefax +41-31-320 68 31  
E-mail: sva@to.aey.ch  
<http://www.atomenergie.ch>  
<http://www.aspea.ch>



**Nordostschweizerische  
Kraftwerke  
Parkstrasse 23  
CH-5401 Baden  
Phone +41-56-200 31 11**



**BKW FMB Energie AG  
Viktoriaplatz 2  
CH-3000 Berne 25  
Phone +41-31-330 51 11**



**Kernkraftwerk  
Gösgen-Däniken AG  
CH-4658 Däniken  
Phone +41-62-288 20 00**



**Kernkraftwerk Leibstadt AG  
CH-5325 Leibstadt  
Phone +41-56-267 71 11**