

Summary of
Operating Experience
in Swiss Nuclear Power Plants

2002

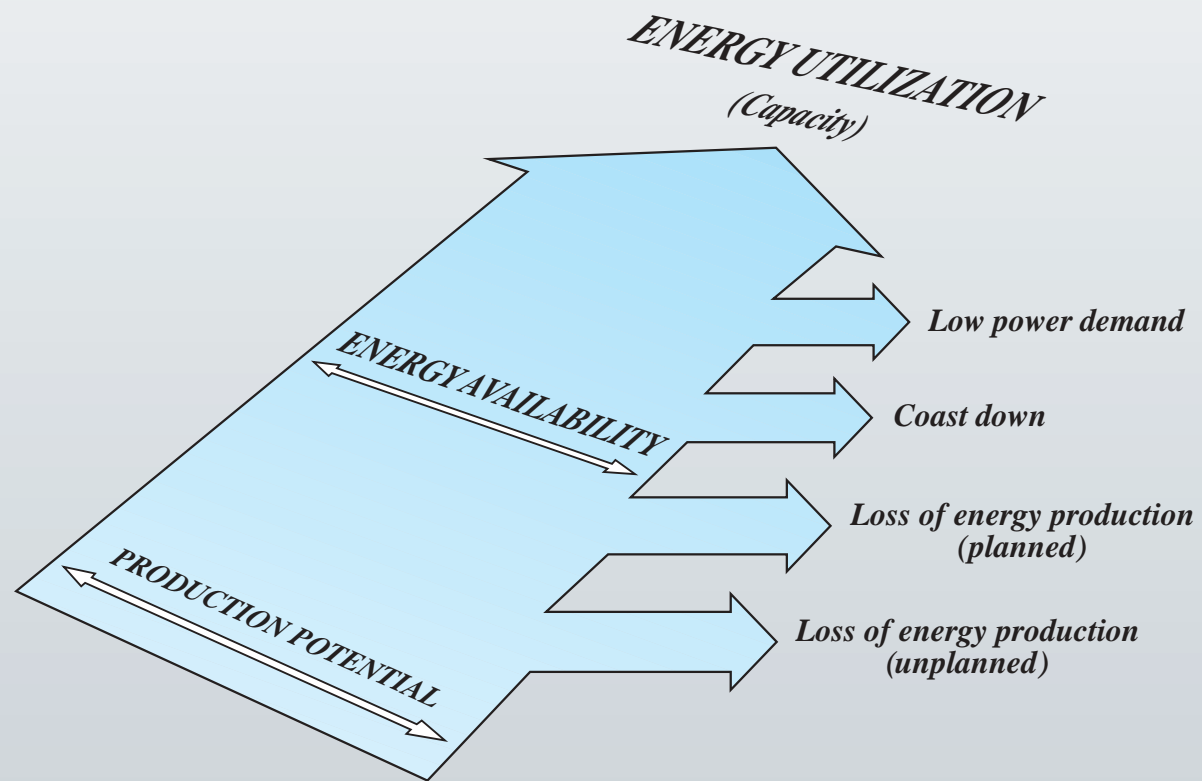

www.atomenergie.ch



Operation of the five Swiss nuclear power plants in 2002 was again very successful, and resulted in an all-time record net production of 25.7 TWh. This was 1.6% higher than the previous year's record of 25.3 TWh, and reflects the efforts invested in first-rate maintenance, personnel training and short annual outages. The backfitting of key plant components have also led to capacity increases during the past years. The 2002 nuclear share of overall electricity production in Switzerland was 39.5%.

According to international statistics, the Swiss nuclear power plant park has in 2002 recovered the top position in the global country list of annual load factors. This achievement confirms the soundness of the investment and operating strategies that have been implemented at these plants. This is, however, no reason for complacency, but should be taken as an incentive to strive for long-term, continuous excellence in the operation of the country's nuclear power plants, in terms of both safety and economics.

By the end of 2002, Switzerland ranked third out of 29 countries on the international list of nuclear power plants' average lifetime load factors. This good performance, and the resulting important nuclear contribution to Switzerland's electricity supply, explain to a large extent the outstanding public acceptance of nuclear energy in the country. In a national vote on May 18, 2003, close to 70% of Swiss citizens refused to shut-down nuclear plants and rejected new, purely political restrictions on the operation of the plants. Under the new Nuclear Law, which will soon come into force, only technical safety criteria will influence the licensing of nuclear plant operation, in particular with respect to lifetime extensions.

Swiss Association for Atomic Energy (SVA)

Bruno Pellaud

Dr. Bruno Pellaud, President

Peter Hählen

Dr. Peter Hählen, Secretary General

SWISS NUCLEAR POWER PLANTS

Power station	Type of reactor	Net output (MWe)	Commercial operation
Beznau (KKB)	PWR	365	Unit 1: Dec. 24, 1969
		365	Unit 2: March 15, 1972
Mühleberg (KKM)	BWR	355	November 6, 1972
Gösgen (KKG)	PWR	970	November 19, 1979
Leibstadt (KKL)	BWR	1165	December 15, 1984

DEFINITIONS

(Corresponding to the UNIPED classification «Statistical Terminology Employed in the Electrical Supply Industry»)

Energy availability factor – Etg/En (UNIPED definition 4.6.03.f)

Energy utilization factor – Ed/En (UNIPED definition 4.5.01)

En (Production Potential)

– energy producible assuming maximum capacity continuously available throughout a specific period

Ed (Energy Utilization)

– energy actually produced within a specific period

Etg (Energy Availability)

– energy producible assuming available capacity during a specific period

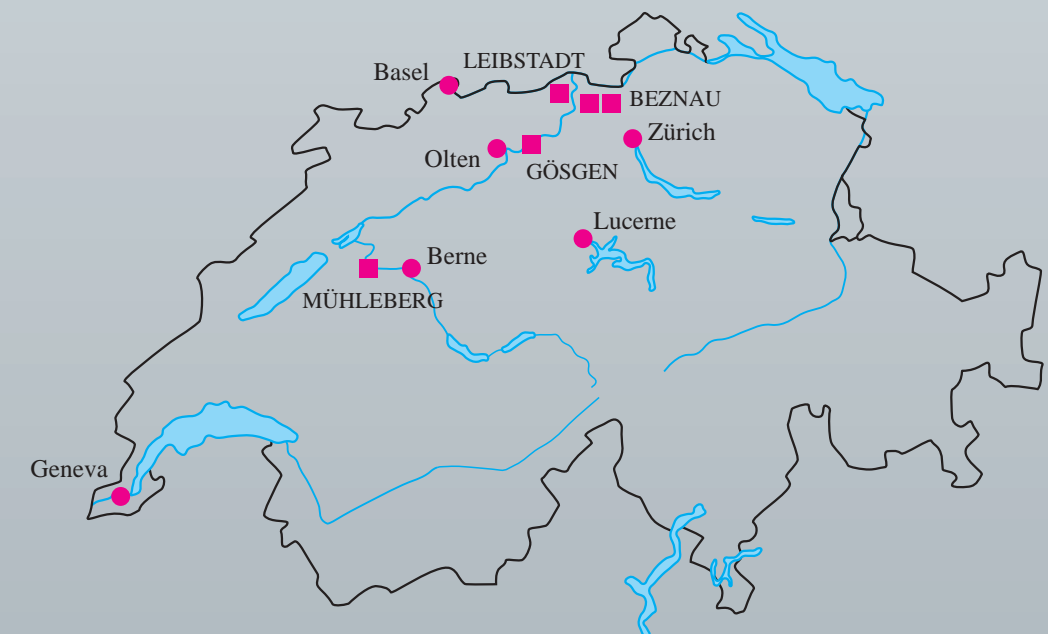

Swiss Nuclear Power Plants: Production Figures 2002 and History

	Gross production MWh	Net production MWh	Total operating time (power production) h	Total gross production since start of operation MWh	Total net production since start of operation MWh
KKB 1	3 034 163	2 908 780	8027	87 106 866	83 324 356
KKB 2	3 137 983	3 012 010	9325	86 512 058	82 886 620
KKM	2 950 430	2 828 213	8292	78 871 943	75 412 701
KKG	8 316 048	7 853 300	8154	180 060 127	169 846 836
KKL	9 635 307	9 173 826	8249.75	148 782 924	104 984 142

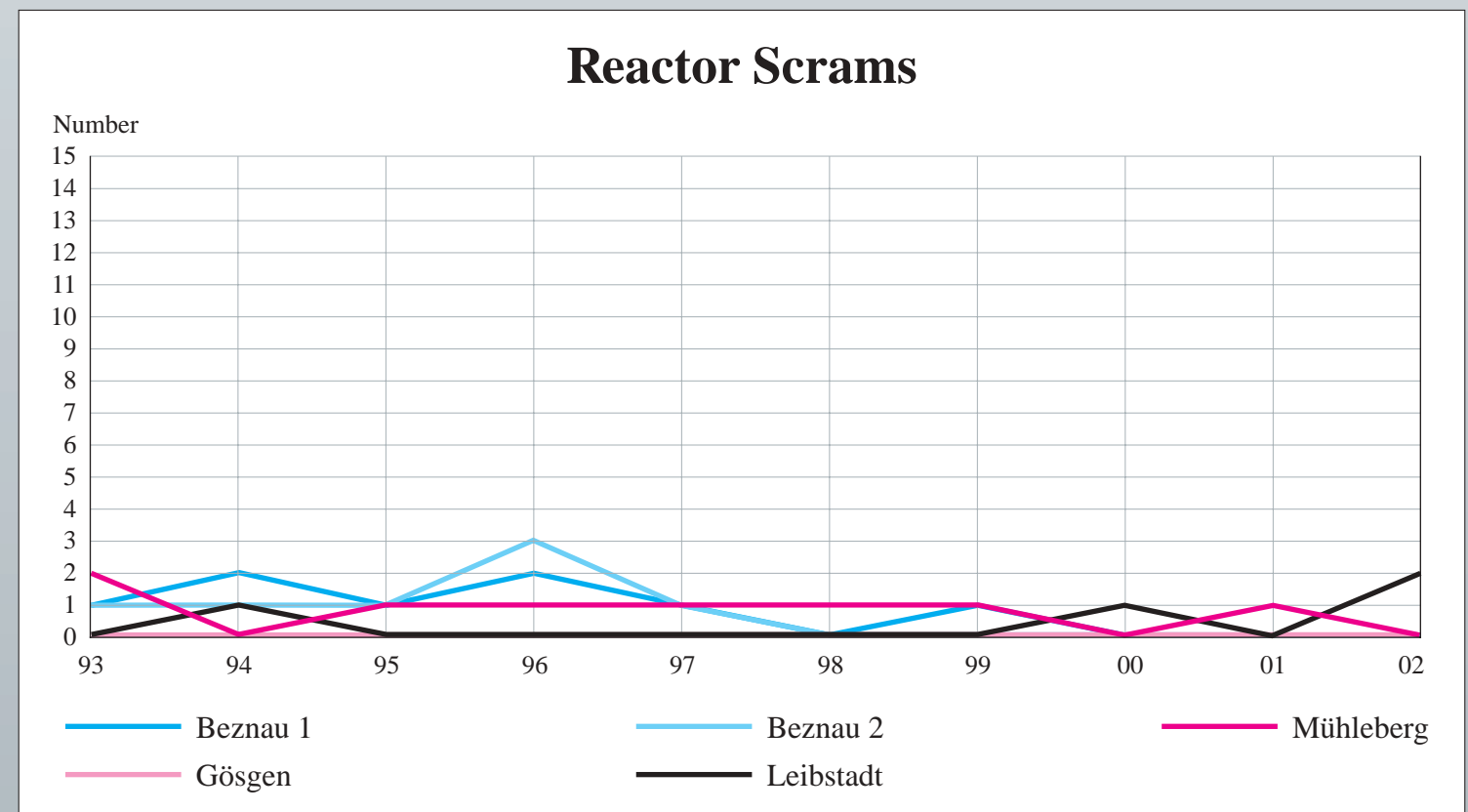
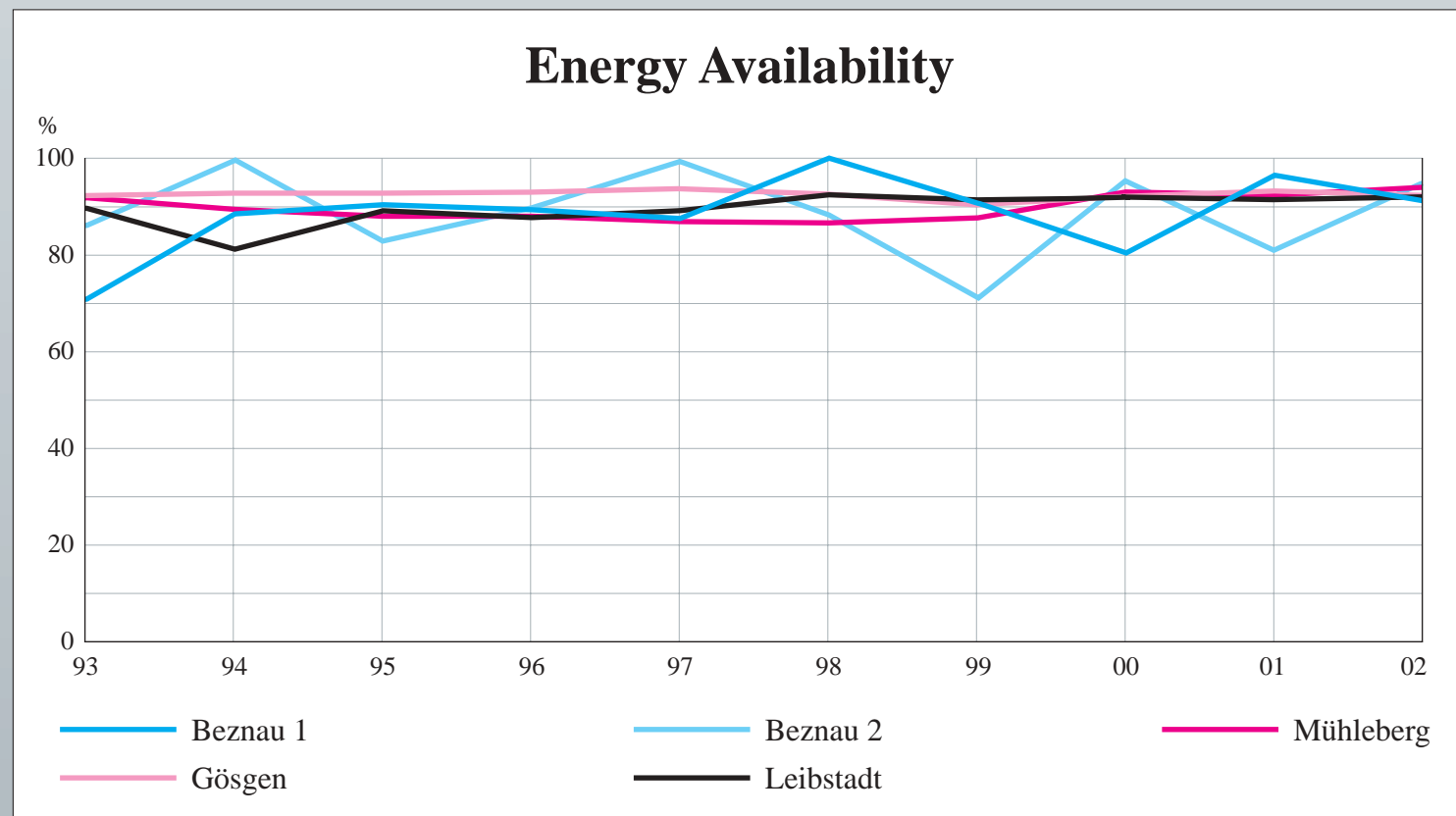
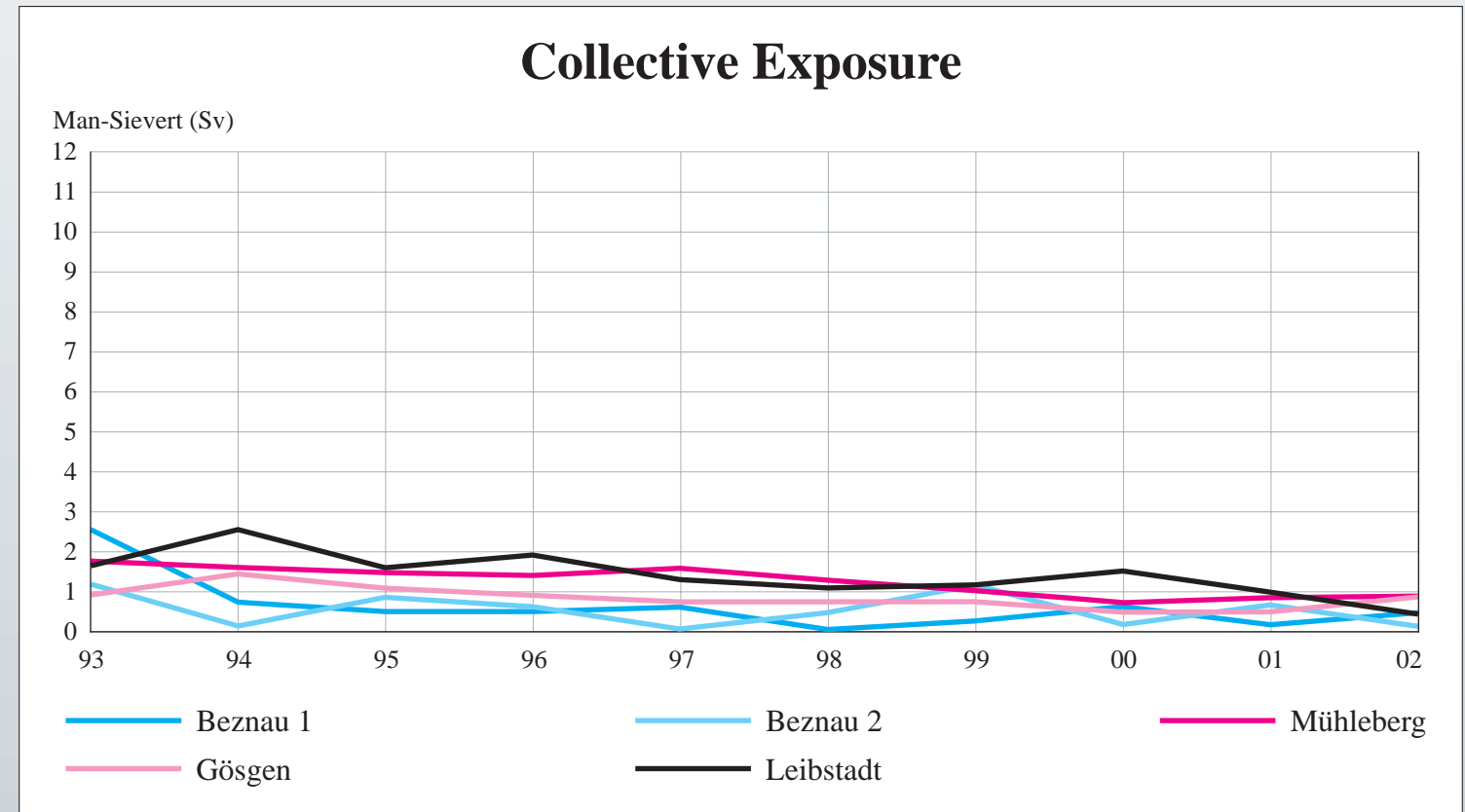

Beznau 1

Operating Experience 2002

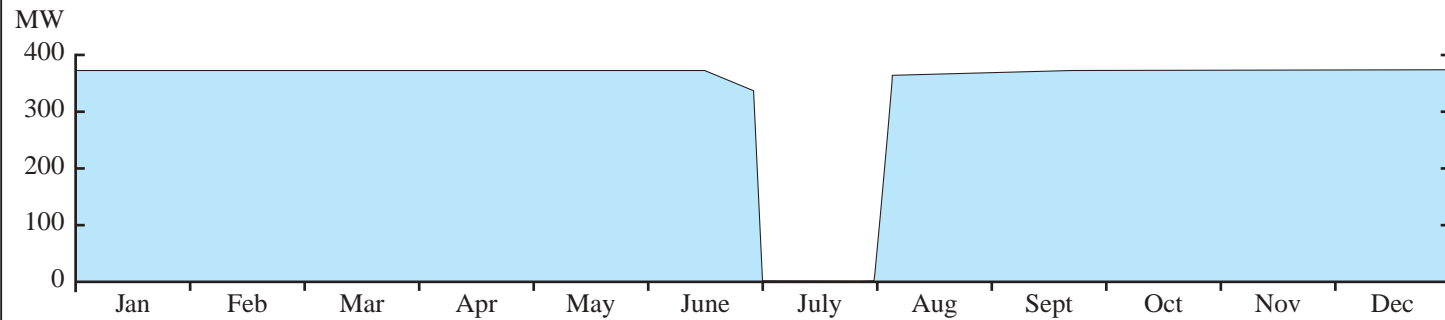

Important to Safety

Scrams:

There was no automatic scram during power operation.

Other:

Year 2002: The environmental management system that is based on the international standard ISO 14001 provided a solid basis for ongoing improvements.

Important to Availability

June 28 to August 1: Beznau 1 was shutdown on June 28 for a refuelling outage after 360 days of full power operation. The refuelling outage lasted four and a half weeks and served to replace 20 of the total of 121 fuel elements. 8 of the new elements contain reprocessed uranium. The pressuriser spray valves (primary system), a reactor coolant pump motor and a station transformer were replaced.

December 31: One of the two turbine-generator sets was separated from the grid to allow a repair to a reserve instrumentation line.

History

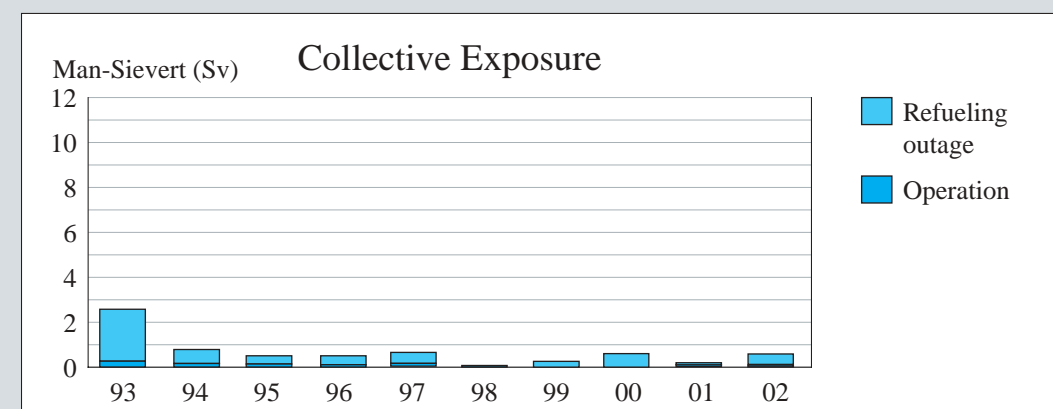
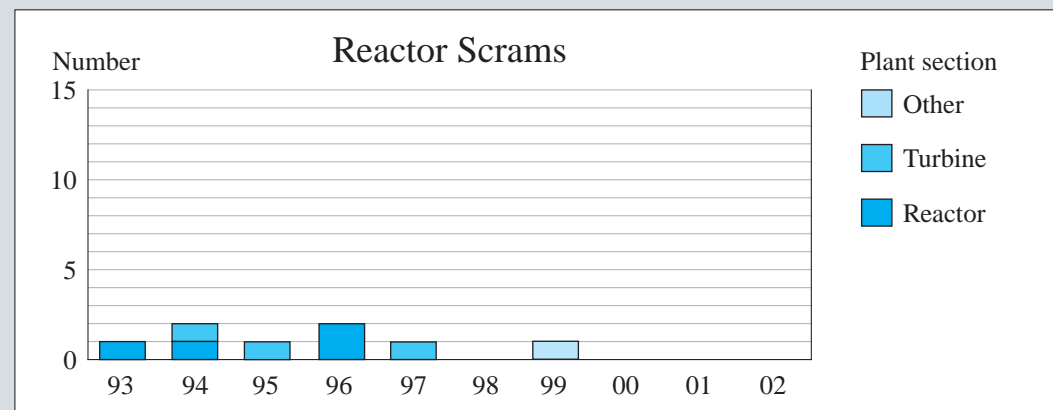
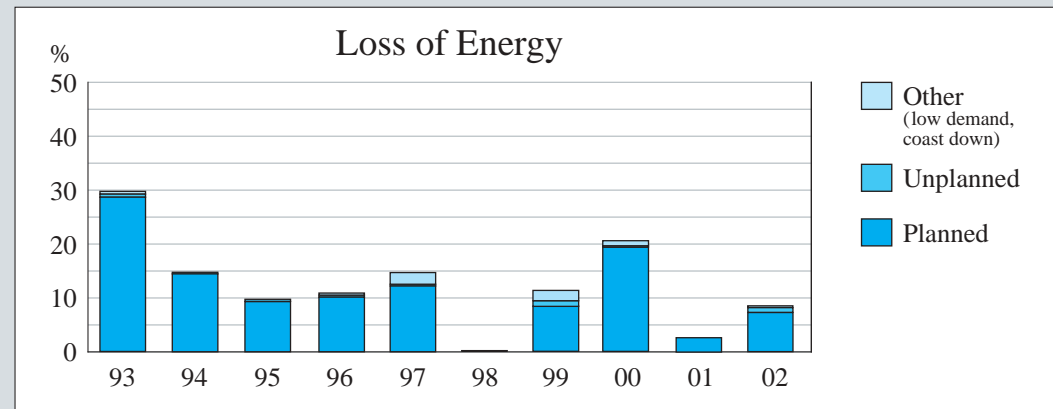
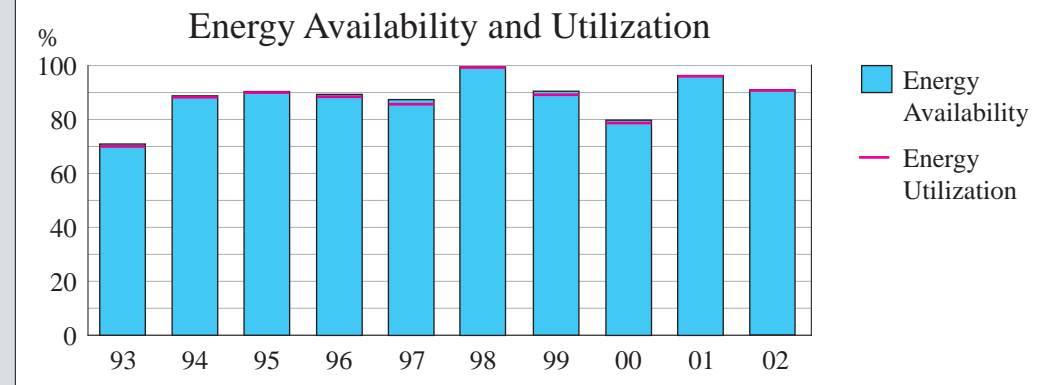

Characteristics

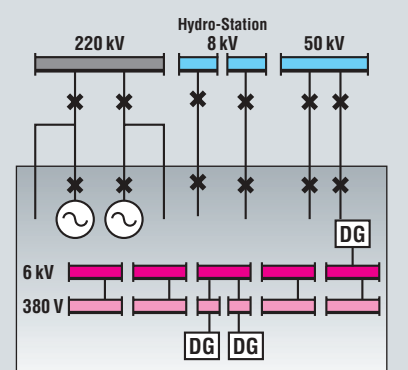
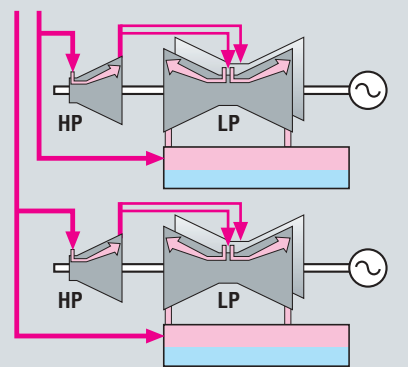
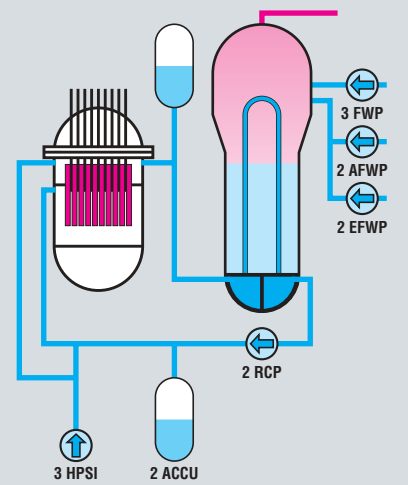
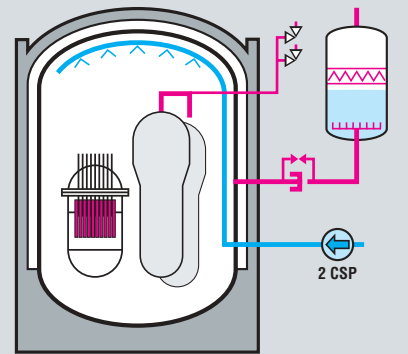

Beznau 2

Operating Experience 2002

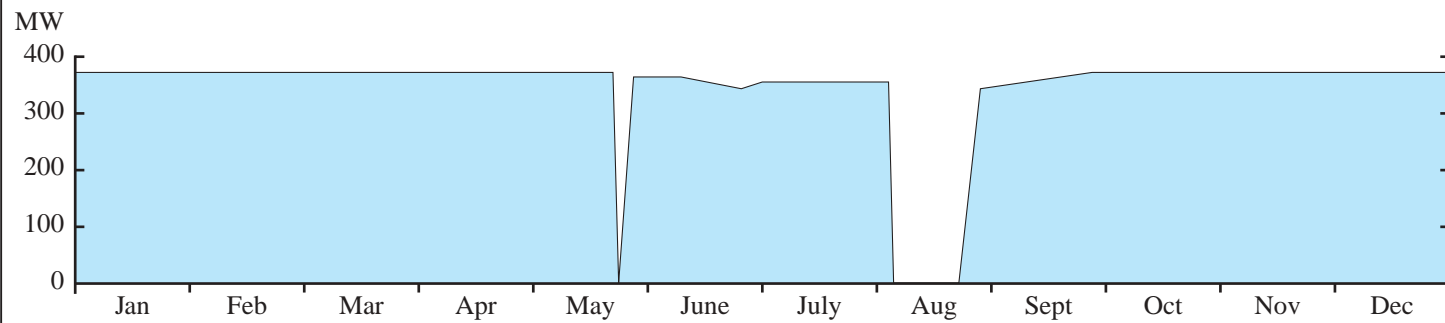

Important to Safety

Scrams:

There was no automatic scram during power operation.

Other:

Mai 27: The unit had to be shut down for eight hours to verify a fault indication, and for the precautionary replacement of a transmitter (current transformer) in the house load switch gear system.

Year 2002: The environmental management system that is based on the international standard ISO 14001 provided a solid basis for ongoing improvements.

Important to Availability

Refuelling outage August 3 to August 24: The refuelling outage – the first short outage within the scope of a so called hybrid cycle – served primarily for the replacement of the irradiated fuel elements. This allowed resumption of power operation after a period of two and a half weeks. The hybrid cycle is based on a first operating year, ending with a short outage for fuel reloading, followed the next year by a full refuelling and maintenance outage. This approach is based on the long experience of plant operators and contractors concerning the behaviour of components and systems, and the use of preventive maintenance, aiming to reduce the average outage period without loss of safety. 24 fuel elements (from a total of 121) have been replaced with new ones: 16 are MOX-elements, while 8 elements contain enriched uranium. The unplanned replacement of two seals in a reactor coolant pump prolonged the outage by 7 days.

History

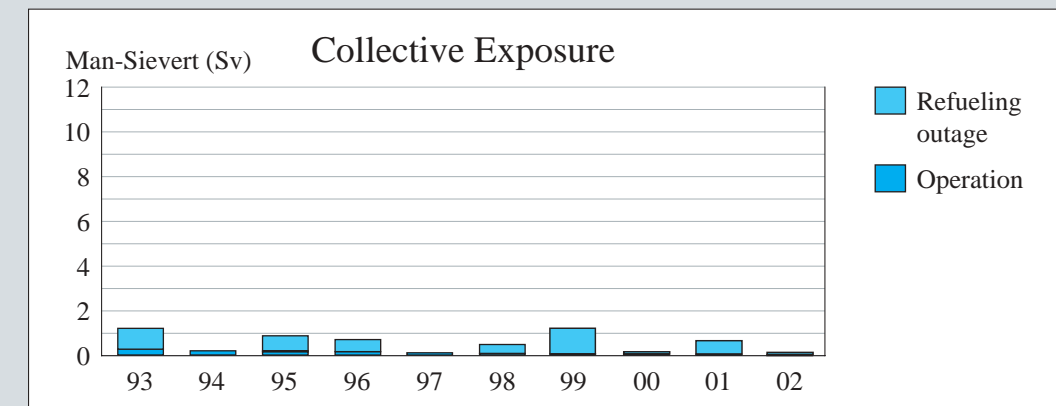
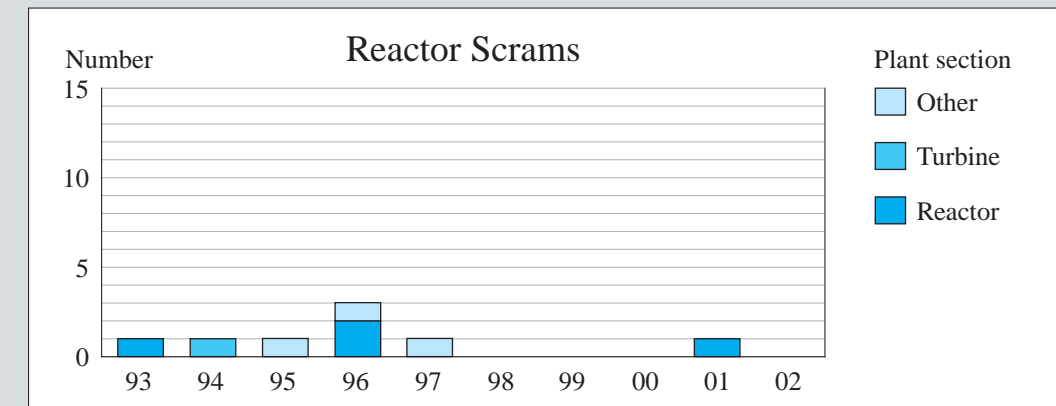
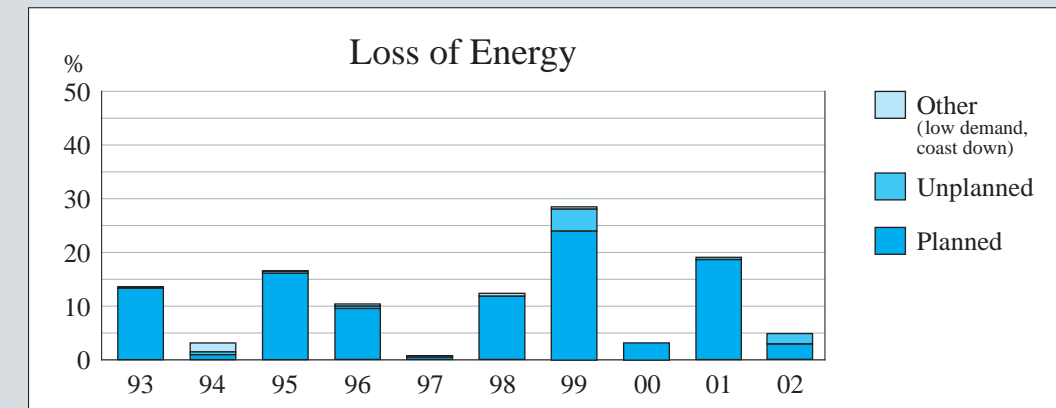
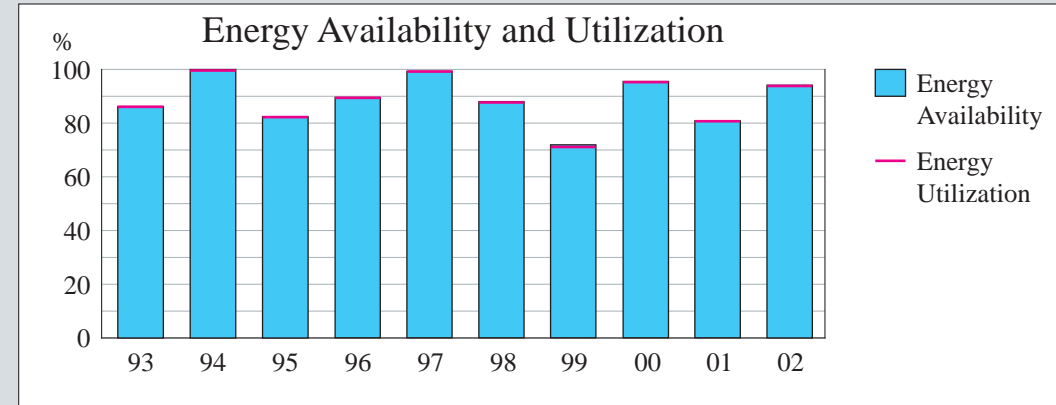

Characteristics

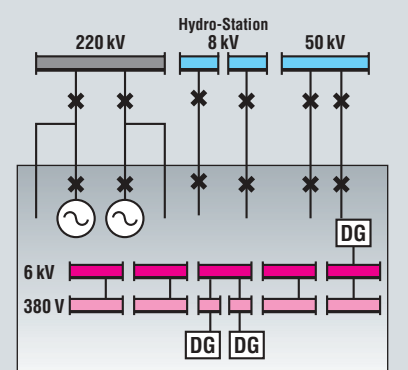
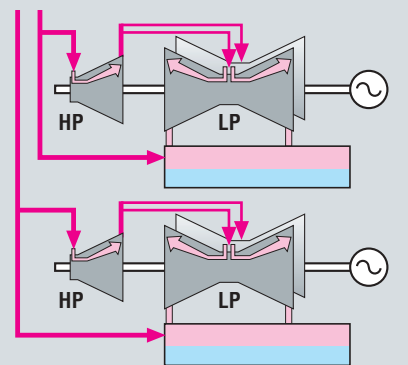
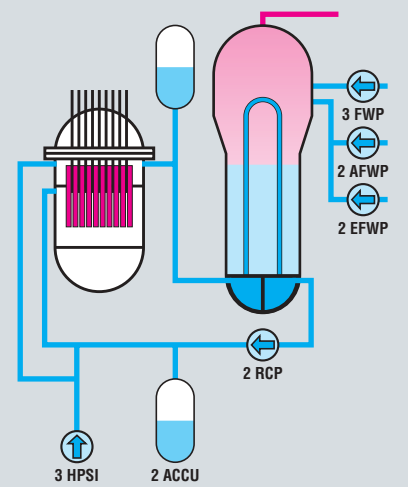
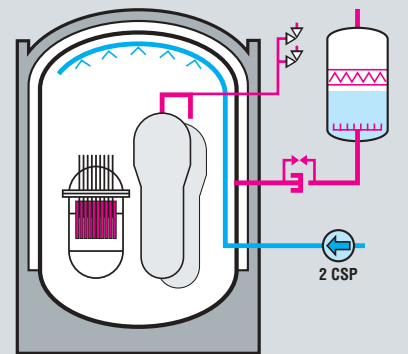

Mühleberg

Operating Experience 2002

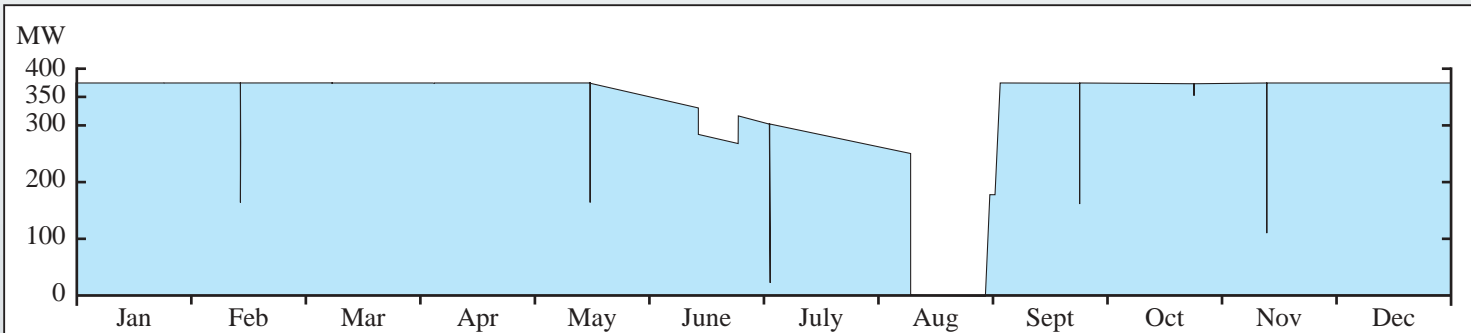

Important to Safety

Scrams:

There was no scram during power operation.

Others:

July 1: Dual turbine load rejection occurred following disturbance in the nearby 220 kV switchyard. Both generators successfully switched on house load.

September 20: Loss of one re-circulation pump due to a malfunction in the speed control system.

In-service inspections and ultrasonic tests of the reactor pressure vessel were successfully carried out during the re-fuelling outage. As usual, inspections of the core shroud were performed. One of the four built-in tie rods was inspected.

Important to Availability

May 21: The planned coast-down operation began. The power at end of cycle reached 73.2%.

Refueling outage August 11 to August 30:

The planned outage lasted 20 days. All fuel elements were inspected with an out-of-core sipping equipment. A small leak was detected and repaired. 40 out of a total of 240 fuel elements were replaced.

Load reductions:

A total of six load reductions (> one full-power hour) occurred.

Two unplanned load reductions took place. The first was caused by a dual generator load rejection to house load, and the second by a re-circulation pump malfunction.

Three planned load reductions were required for periodic surveillance tests, combined with rod pattern adjustments and preventive maintenance.

One planned load reduction was made due to the high temperature of the cooling water.

History

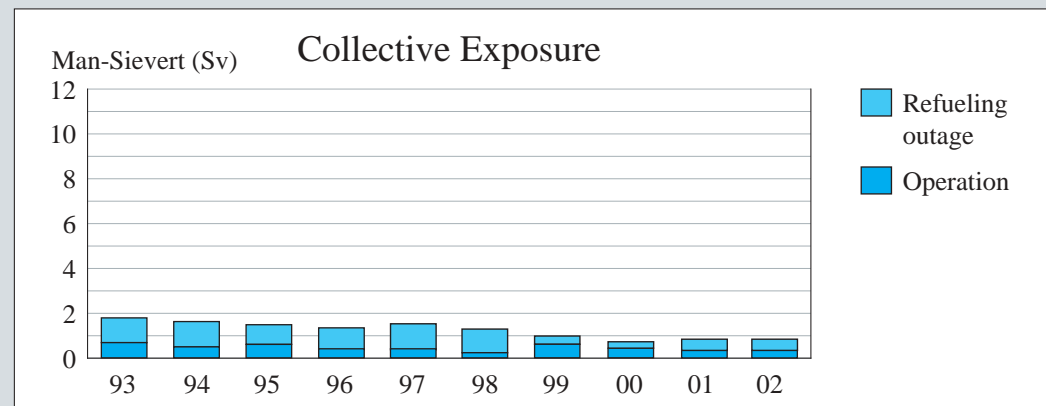
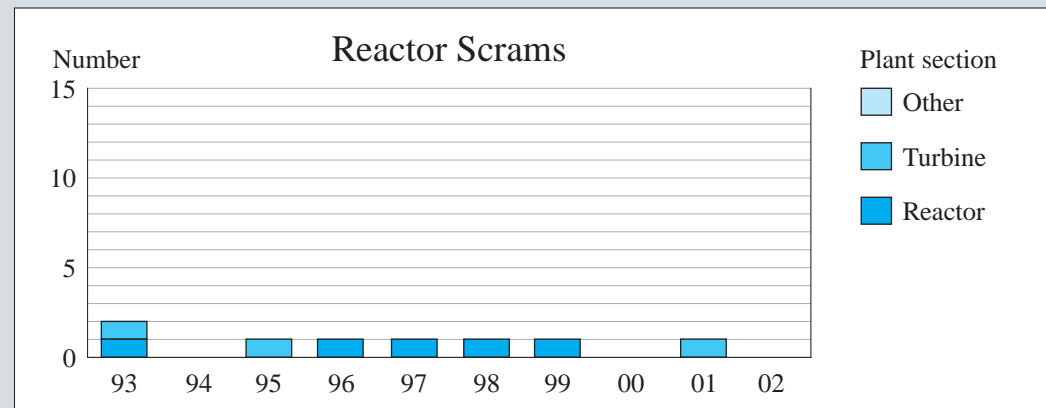
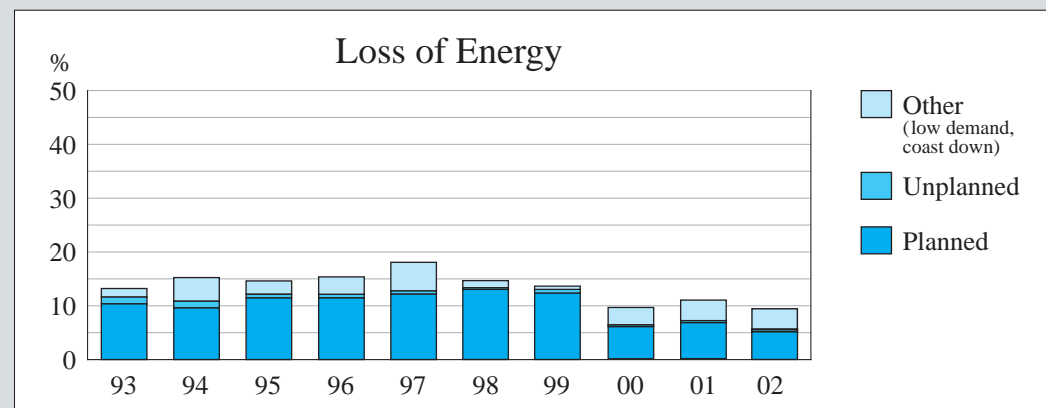
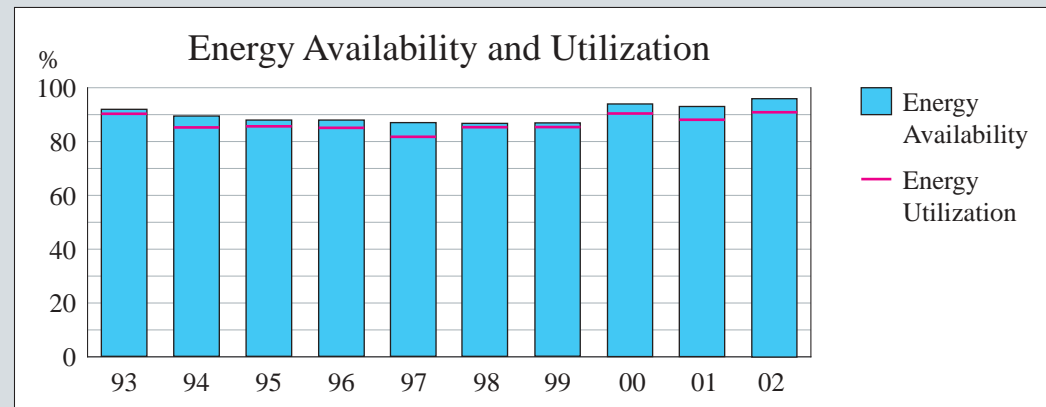

Characteristics

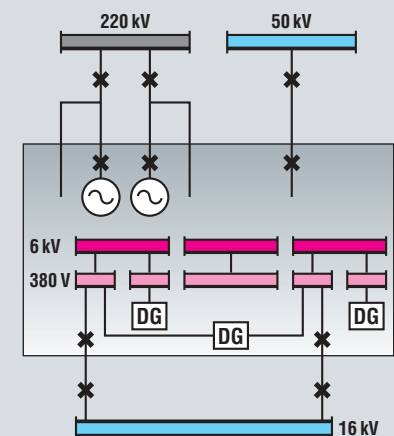
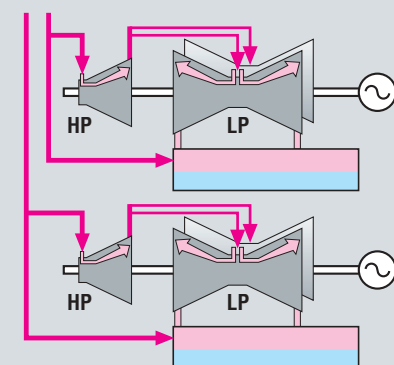
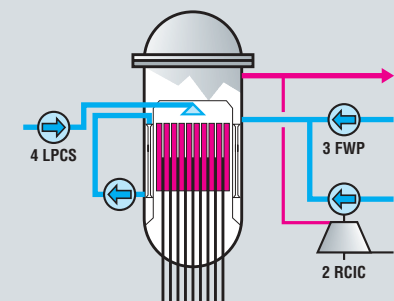
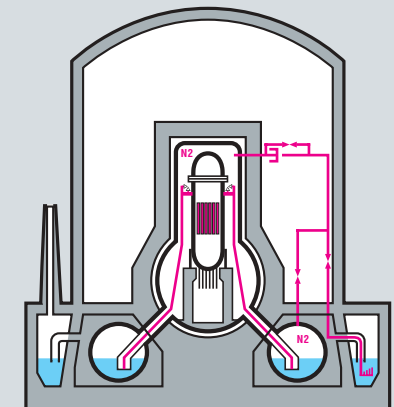

Operating Experience 2002

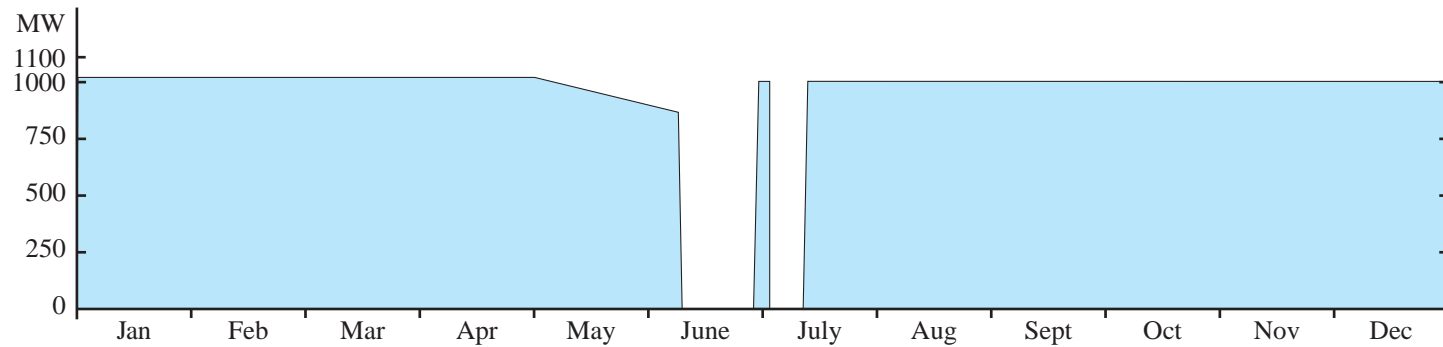

Important to Safety

Scrams: 2002 was the twelfth consecutive year of operation without unplanned scrams.

Important to Availability

April 30: Start of coast-down operation. The power level at the end of the cycle was 89%. Coast-down operation led to a production loss of about 2 equivalent full-power days.

Refuelling outage June 8 to June 28:

The duration of the re-fuelling outage was 20 days as scheduled.

In addition to general preventive maintenance and inspection work, the following major work was performed:

- Inspection of a pressuriser surgeline-nozzle.
- U-tube eddy current testing on all three steam generators.
- Replacement of shaft seals on two main coolant pumps.
- Modifications on turbine revolution counter.
- Replacement of the 400 kV surge protectors.
- Loading of 40 new fuel elements. The newly loaded fuel includes 28 ERU fuel elements.

June 28: After plant start-up and power ascension to 85%, the pressure monitor of the Reactor vessel head double seal was actuated. The drain line isolation valve closed automatically.

Further investigations convinced a leakage on the inner sealingring of the reactor vessel head. To prevent additional leakage on the outer sealingring, it was decided that the plant should shut down after preparation of the repair work.

July 1 to July 7: Cold shut-down of the plant to repair the leak on the inner sealingring of the reactor vessel head. The inner seal nut on the reactor vessel head showed several corrosion pits with about 1,5 mm in diameter and 0,2 mm in depth. On ten positions in the nut, the corrosion pits were repaired by welding.

The corrosion was probably caused by chlorides of different sources, such as tools.

History

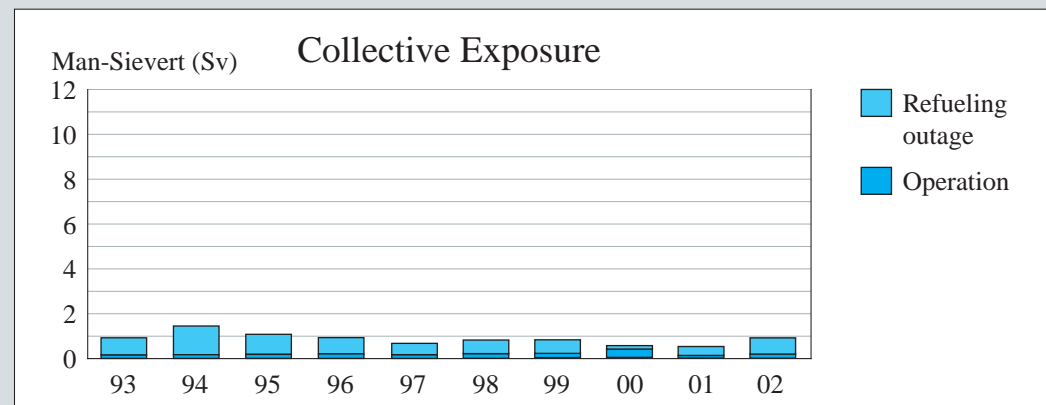
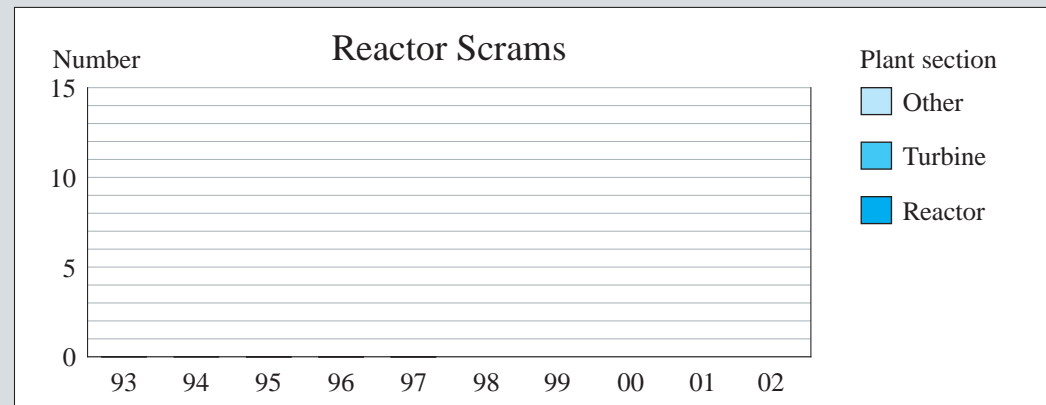
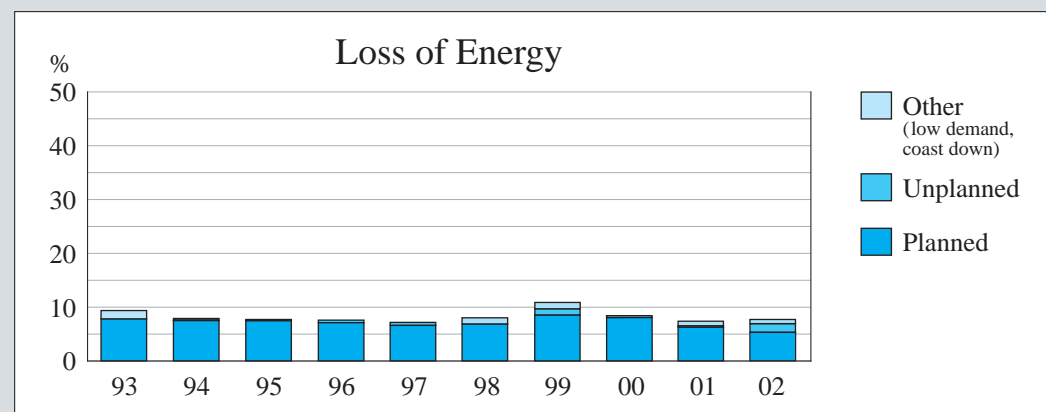
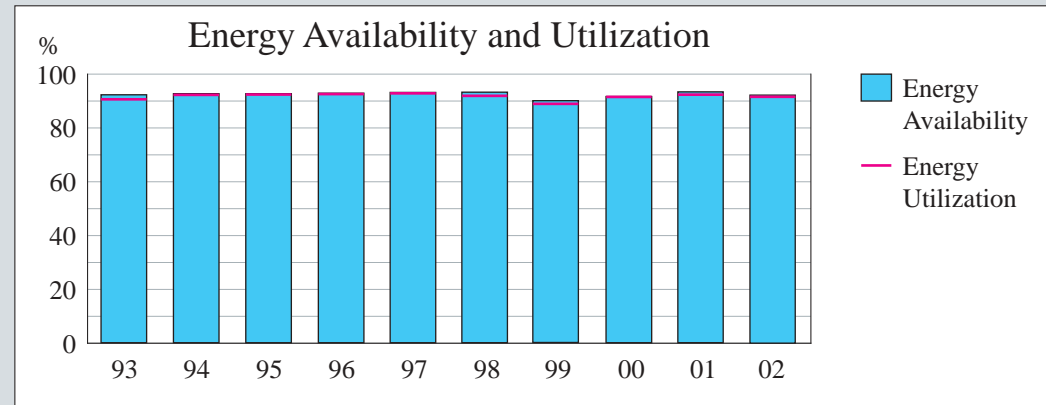

Characteristics

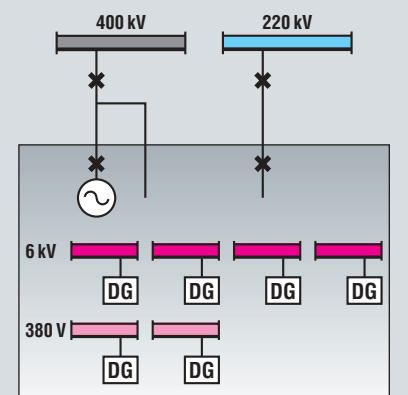
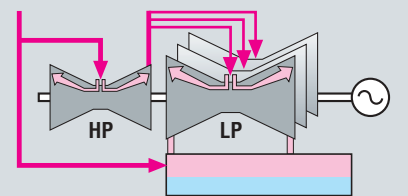
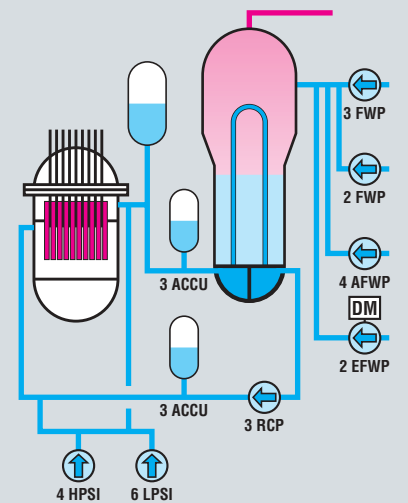
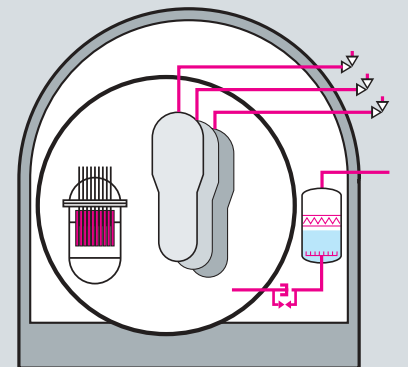

Leibstadt

Operating Experience 2002

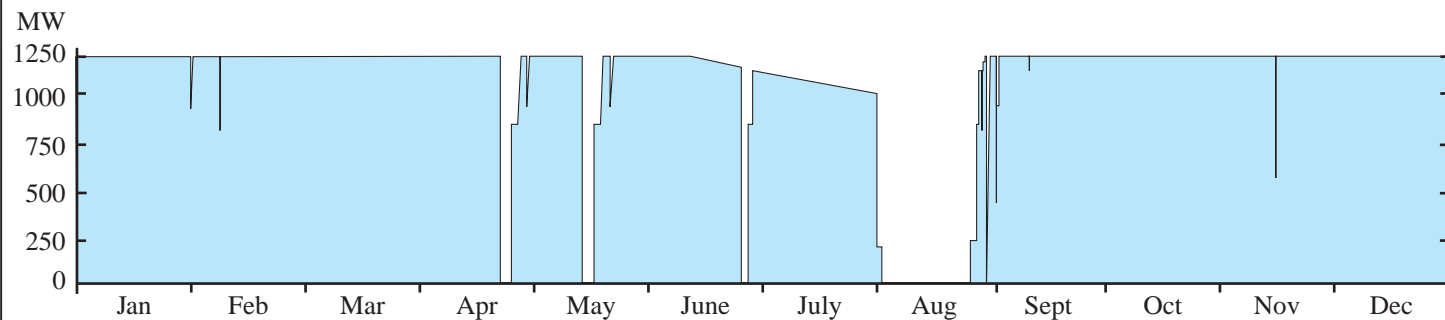

Important to Safety

Scrams:

There were two (2) automatic scrams during power operation.

April 23: Loss of 420 kV off-site power due to the failure of Main Transformer Phase R overvoltage protection device. The plant responded per design: 50 kV power was available but the 10 kV major in-house loads were shed resulting in a «Turbine Island Scram» scram signal.

June 26: Improper restoration of power following 24 VDC battery 11FM capacity test initiated Alternate Rod Insertion (ARI) scram signal.

Other:

August 26: Increased reactor power to 3600 MWth, thus completing the Extended Power Uprate Programme.

Important to Availability

January 31: Disturbance caused the «B» Reactor Recirculation System Flow Control Valve to close.

February 9: MSIV monitoring and control rod pattern adjustment.

April 23: Control rod pattern adjustment.

May 17: Planned plant shutdown to repair the Main Transformer Phase R overvoltage protection device.

May 24: Control rod pattern adjustment.

June 12: Start end-of-cycle coast-down

August 3 – 20: 18th refueling outage

Duration was 16.8 days (scheduled 16.2). Loaded 140 new fuel bundles and 3 re-inserts (out of 648)

August 20 – 26: Plant start-up; various planned Power Uprate tests; unplanned Feedwater Pump trip, control rod pattern adjustments; power ascension to rated power.

August 27: Planned Main Turbine Trip Test for post-modification testing purpose; resynchronisation to the grid; power ascension.

September 1: Planned Stability Test.

September 13: Control rod pattern adjustment.

November 17: Feedwater Pump RL21 trip.

History

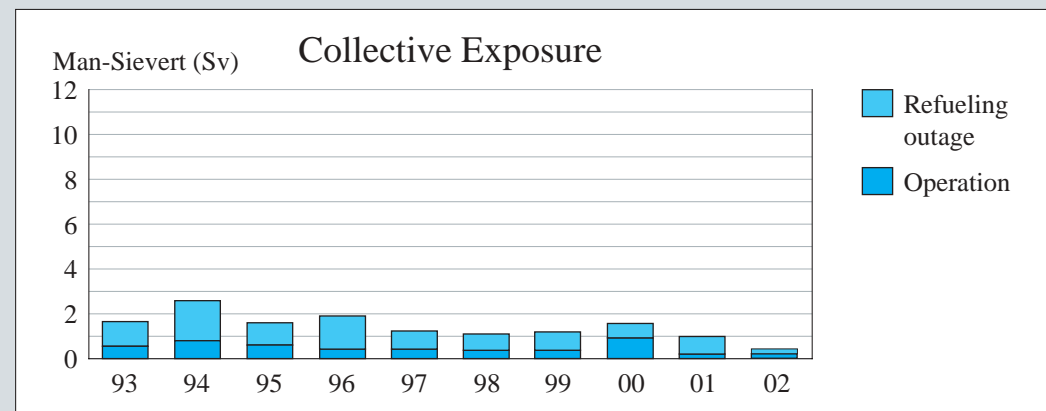
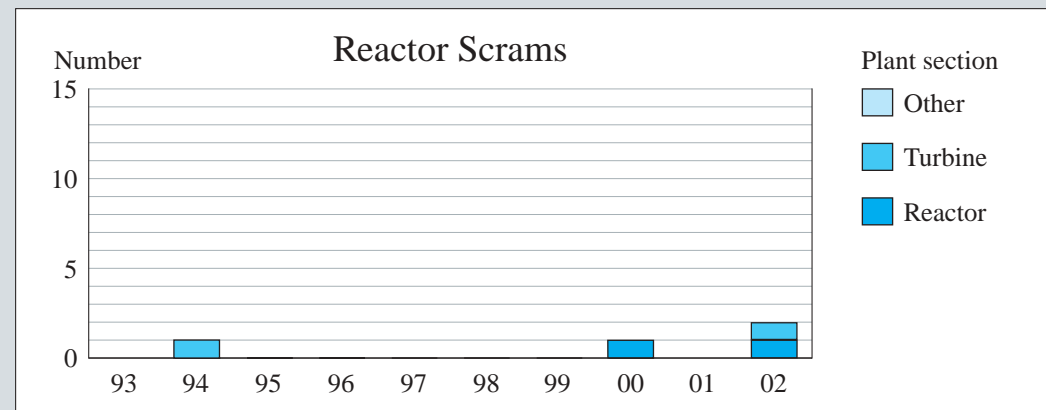
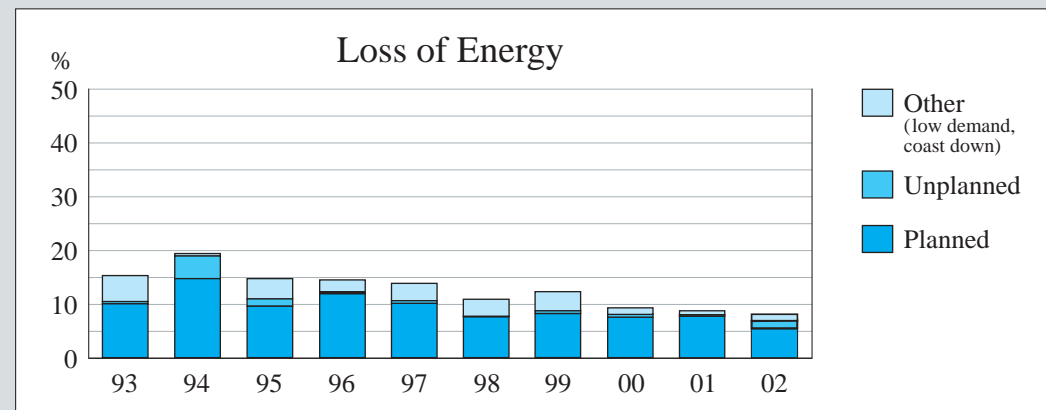
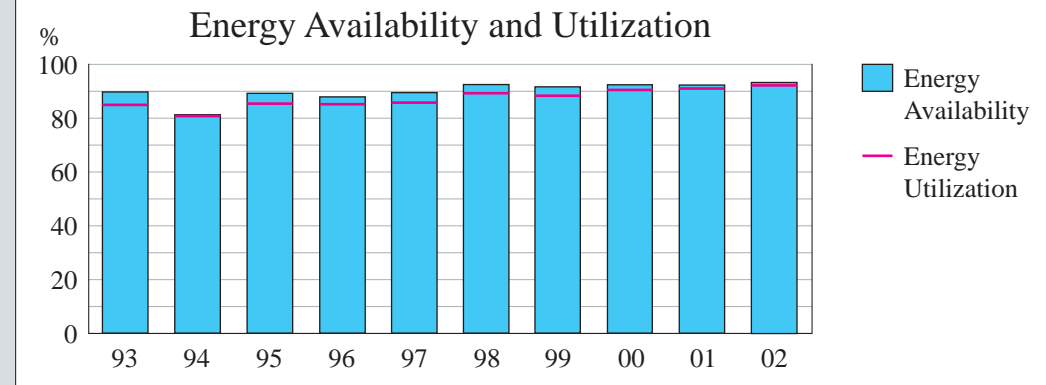

Characteristics

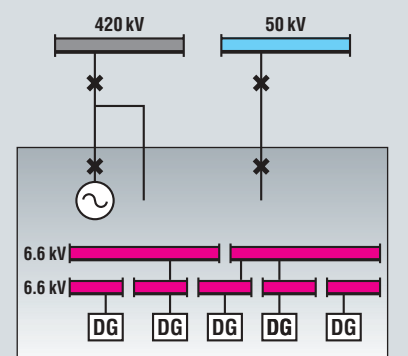
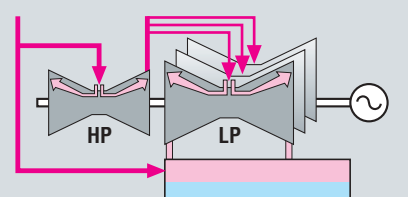
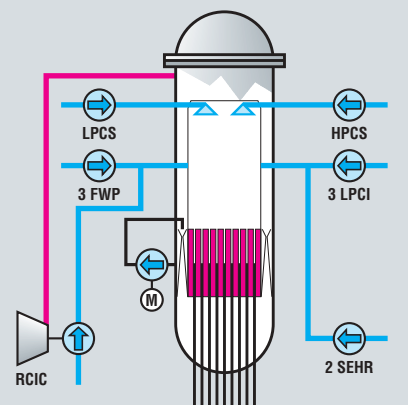
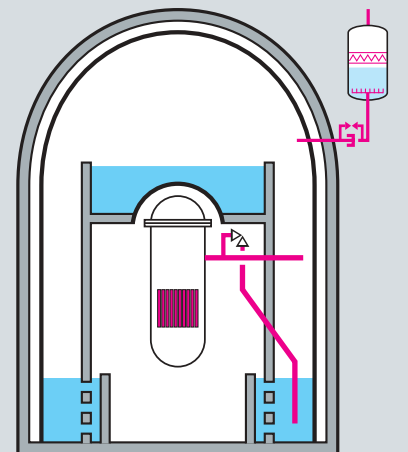

The first two Swiss nuclear power plants, Beznau and Mühleberg, each belong to a single large public electric utility, whereas the two later plants, Gösgen and Leibstadt, are partner plants of several electric utilities and public service companies. The concept of partner nuclear power plants made it possible, when they were set up in the seventies, for medium-sized and smaller organisations to share in economically attractive, large-scale power generation plants and to gain access to the latest technology. In each case one of the partners has responsibility for the business management on behalf of the others.

The Beznau nuclear power plant is fully owned by its operator, Nordostschweizerische Kraftwerke.

Likewise, the Mühleberg nuclear power plant belongs fully to BKW FMB Energie AG.

The partners of Kernkraftwerk Gösgen-Däniken AG (KKG) are:

- Aare-Tessin AG für Elektrizität (ATEL, 40%, managing partner)
- Nordostschweizerische Kraftwerke (NOK, 25%)
- the City of Zurich (15%)
- Centralschweizerische Kraftwerke (CKW, 12.5%)
- The City of Berne (7.5%)

Kernkraftwerk Leibstadt AG (KKL) is owned by the following partners:

- Nordostschweizerische Kraftwerke AG (NOK, 22.8%, managing partner)
- Aare-Tessin AG für Elektrizität (ATEL, 27.37%)
- Elektrizitäts-Gesellschaft Laufenburg AG (EGL, 16.28%)
- Centralschweizerische Kraftwerke (CKW, 13.57%)
- BKW FMB Energie AG (9.55%)
- AEW Energie AG (5.43%)
- Energie Ouest Suisse, Lausanne (EOS, 5%)

Copies of this report are available from:
Swiss Association for Atomic Energy (SVA)
P.O.Box 5032
CH-3001 Berne
Phone +41-31-320 65 25
Telefax +41-31-320 68 31
E-mail: sva@to.aey.ch
www.atomenergie.ch
www.aspea.ch



**Nordostschweizerische
Kraftwerke
Parkstrasse 23
CH-5401 Baden
Phone +41-56-200 31 11**



**BKW FMB Energie AG
Viktoriaplatz 2
CH-3000 Berne 25
Phone +41-31-330 51 11**



**Kernkraftwerk
Gösgen-Däniken AG
CH-4658 Däniken
Phone +41-62-288 20 00**



**Kernkraftwerk Leibstadt AG
CH-5325 Leibstadt
Phone +41-56-267 71 11**