

June 2001

Summary of  
**Operating Experience**  
in Swiss Nuclear Power Plants

2000

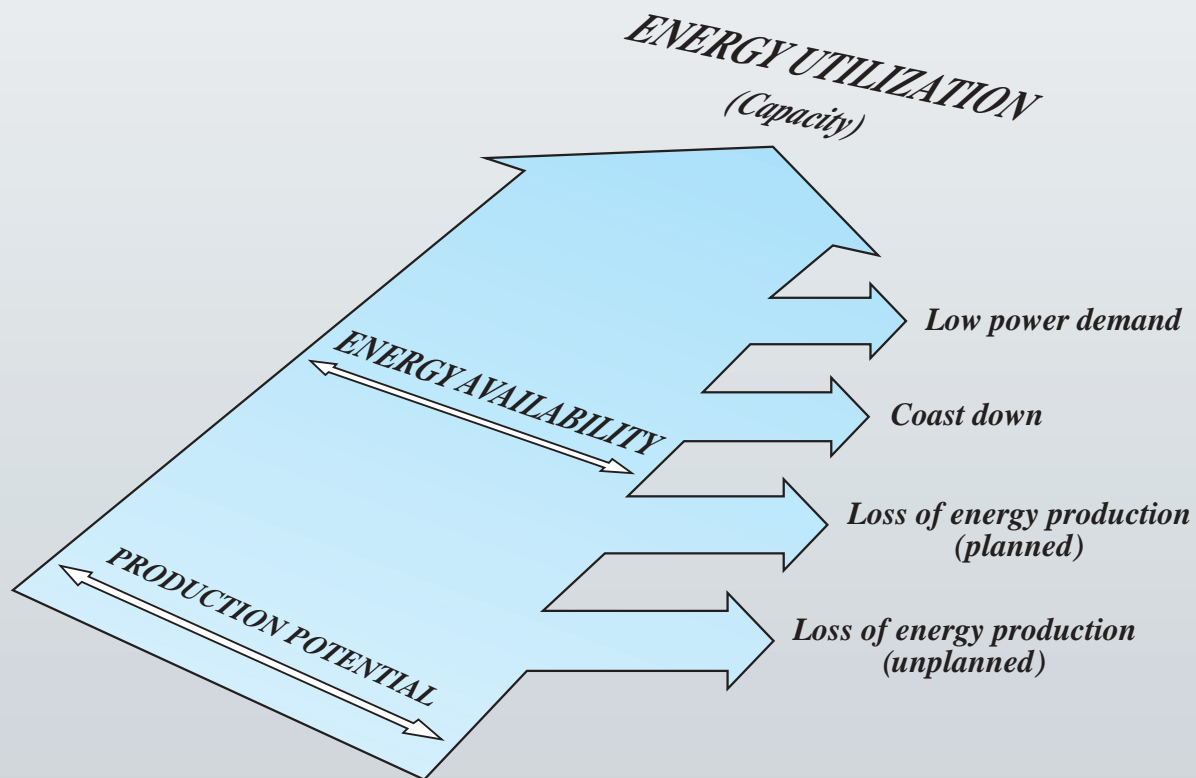



## SWISS NUCLEAR POWER PLANTS

Power station	Type of reactor	Net output (MWe)	Commercial operation
Beznau (KKB)	PWR	365	Unit 1: Dec. 24, 1969
		365	Unit 2: March 15, 1972
Mühleberg (KKM)	BWR	355	November 6, 1972
Gösgen (KKG)	PWR	970	November 19, 1979
Leibstadt (KKL)	BWR	1145 <sup>1</sup>	December 15, 1984

<sup>1</sup>as of January 1, 2001

## DEFINITIONS

(Corresponding to the UNIPED classification «Statistical Terminology Employed in the Electrical Supply Industry»)

Energy availability factor –  $E_{tg}/E_n$   
(UNIPED definition 4.6.03.f)

Energy utilization factor –  $E_d/E_n$   
(UNIPED definition 4.5.01)

$E_n$  (Production Potential)

– energy producible assuming maximum capacity continuously available throughout a specific period

$E_d$  (Energy Utilization)

– energy actually produced within a specific period

$E_{tg}$  (Energy Availability)

– energy producible assuming available capacity during a specific period

In 1997, Switzerland's five nuclear power units achieved their highest-ever combined annual net output: 24,97 TWh. This was 2,5% higher than the previous record (24,45 TWh in 1998). The nuclear share in overall electricity production was 38,2%, also somewhat higher than the previous year's figure.

The millenium calendar change-over did not cause problems for plant operation, and there was only one automatic scram during power operation, in Leibstadt.

With the exception of Beznau 1, all refueling and maintenance outages were once again short. The Leibstadt outage lasted 25 days, Gösigen 27 days, Beznau 1 lasted 70 days, Beznau 2 12 days and Mühleberg 20 days.

At Gösigen, MOX fuel was loaded for the fourth time in 2000. Of the 44 freshly-loaded fuel elements, 20 were MOX and 4 were ERU fuel elements. MOX fuel has already been used for 22 years at Beznau.

Non-electrical energy delivery by Beznau and Gösigen continued to function flawlessly. Beznau delivered 132 GWh of the thermal energy to the Refuna district heating system, while Gösigen supplied 174 GWh of process heat to the nearby Niedergösigen cardboard factory.

Swiss Association for Atomic Energy (SVA)

Dr Hans Jörg Huber, President

Dr Peter Hählen, Secretary General

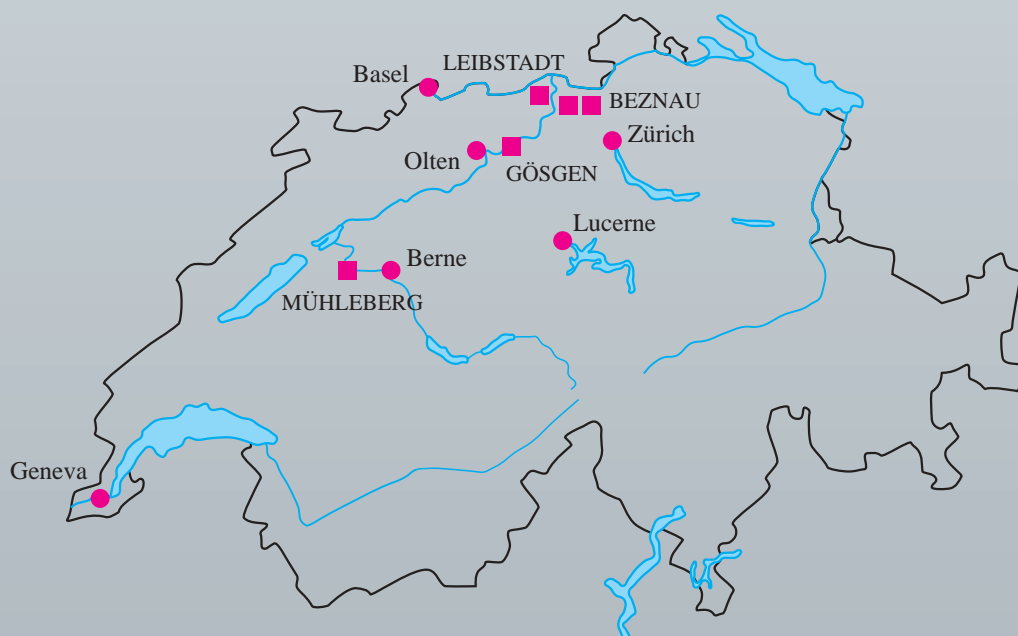

# Swiss Nuclear Power Plants: Production Figures 2000 and History

	Gross production MWh	Net production MWh	Total operating time (power production) h	Total gross production since start of operation MWh	Total net production since start of operation MWh
KKB 1	2 650 092	2 538 196	7113	80 851 102	77 325 399
KKB 2	3 198 427	3 071 026	8499	80 697 030	77 306 883
KKM	2 936 680	2 817 031	8290	73 132 373	69 815 755
KKG	8 267 592	7 804 245	8103	163 405 059	154 123 061
KKL	9 272 934	8 823 189	8159.25	129 601 088	122 720 543

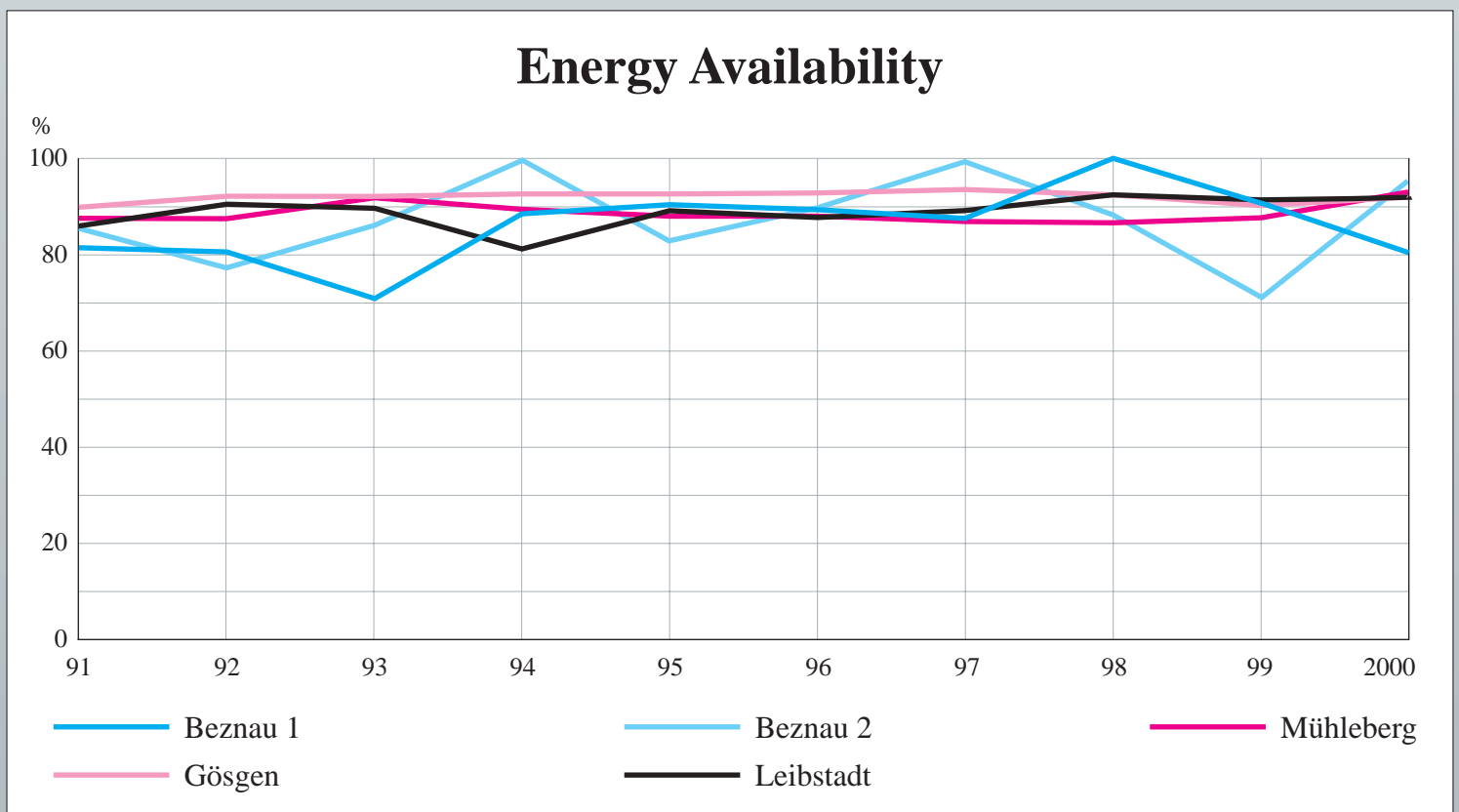

## Collective Exposure

Man-Sievert (Sv)

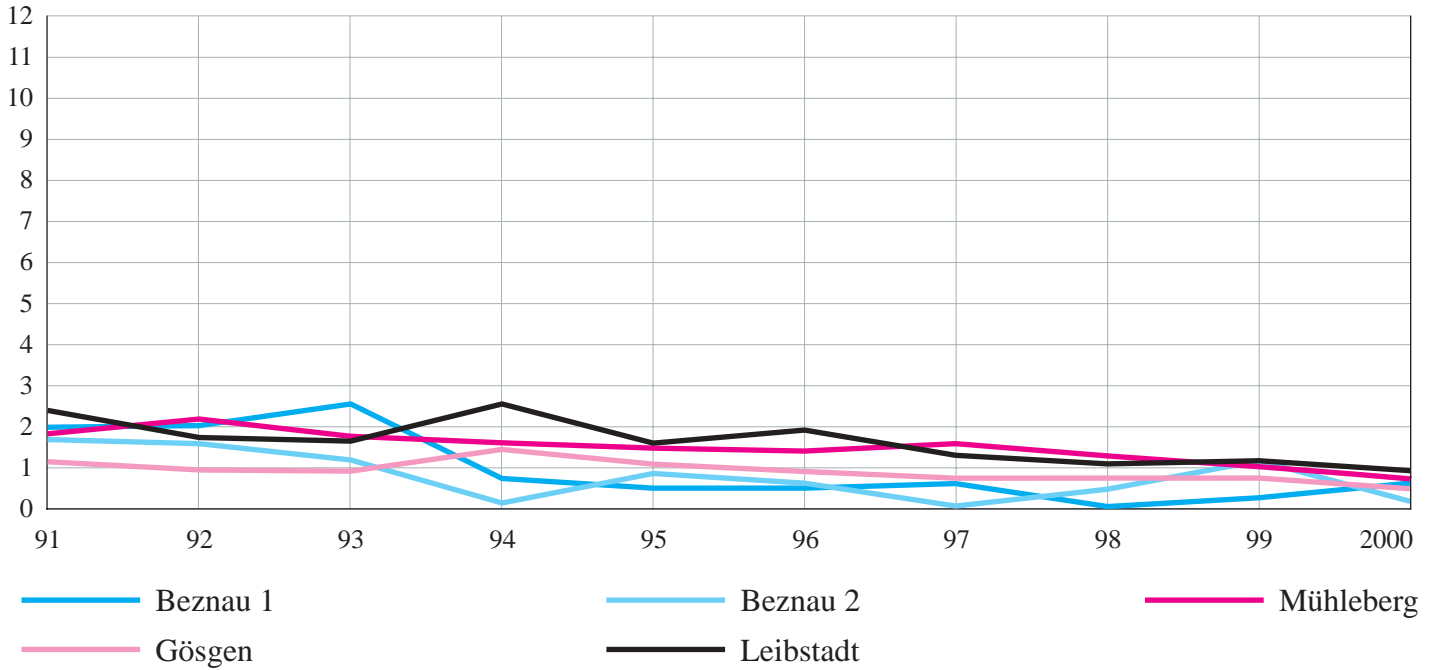

## Reactor Scrams

Number

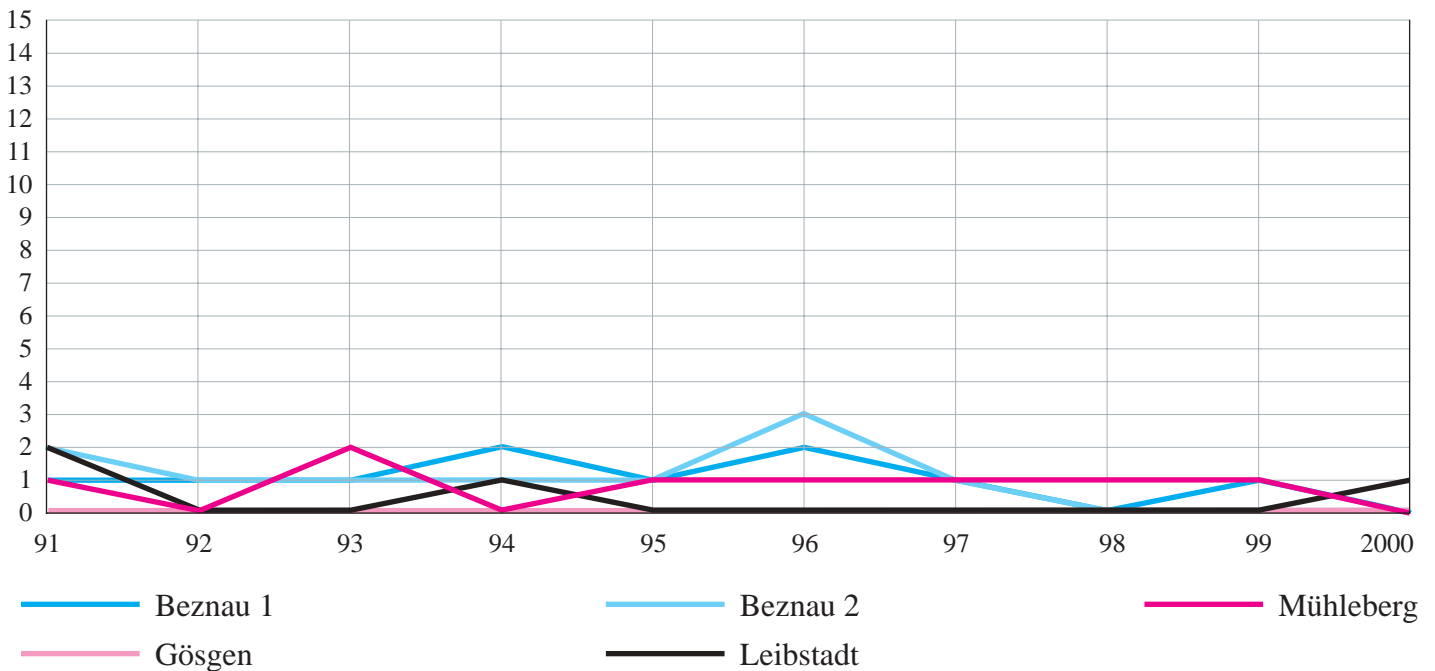

# Beznau 1

## Operating Experience 2000

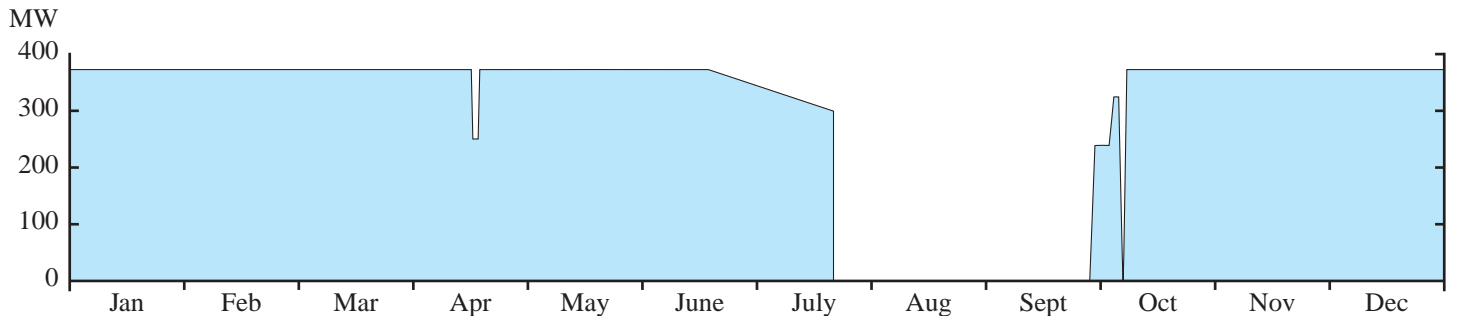

### Important to Safety

#### Scrams:

There were no automatic scrams during power operation.

#### Other:

**December 31:** The millennium calendar change-over did not cause problems for plant operation. The careful analysis and preparations carried out at the technical level over a period of several years bore fruit. The combination of internal precautionary measures and arrangements made within the energy sector as a whole, resulted in an incident-free millennium changeover as in a normal year.

### Important to Availability

**April 23/24 (Easter weekend):** Load was reduced by about 30 % due to (external) requirements of grid load management.

**June 24:** End-of-cycle coast-down due to core reactivity reduction. The power level was eventually decreased to 78 %.

**July 20 to October 7:** During the refuelling outage, the reactor protection and control system including the safe power supply was completely replaced. On September 28 the plant was put into operation again and synchronised with the grid, at first at 50 % of nominal capacity. Until October 7, when full power was reached, all the necessary tests took place, comprising fast load changes, a load interruption and a turbine outage with succeeding reactor trip. All tests took their normal course, the central control system met all expectations. During the refuelling outage, some further revisions were carried out, such as the installation of an additional feedwater supply for the steam generator or the replacement of the fire alarm control system.

# History

# Characteristics

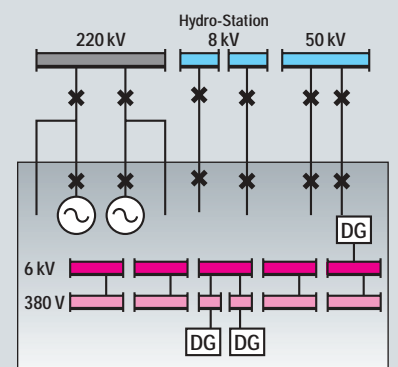
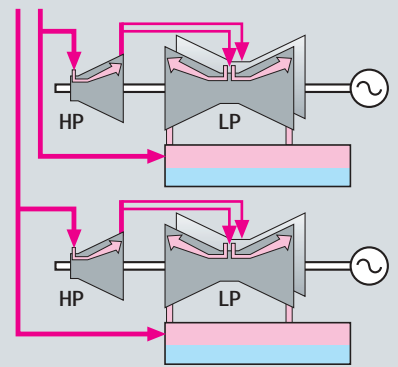
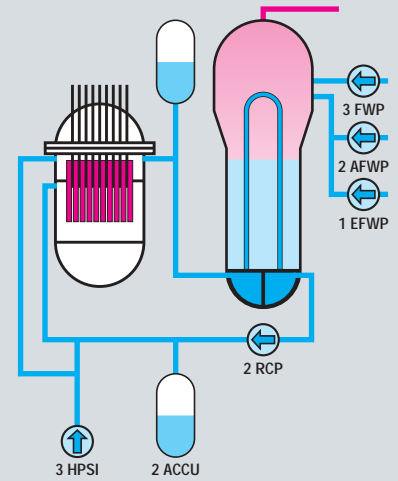
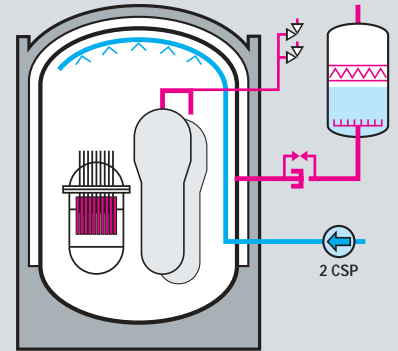
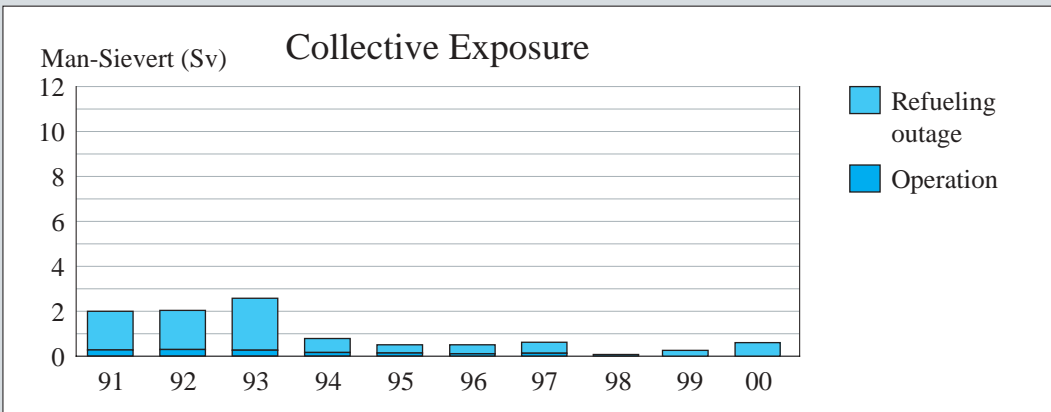
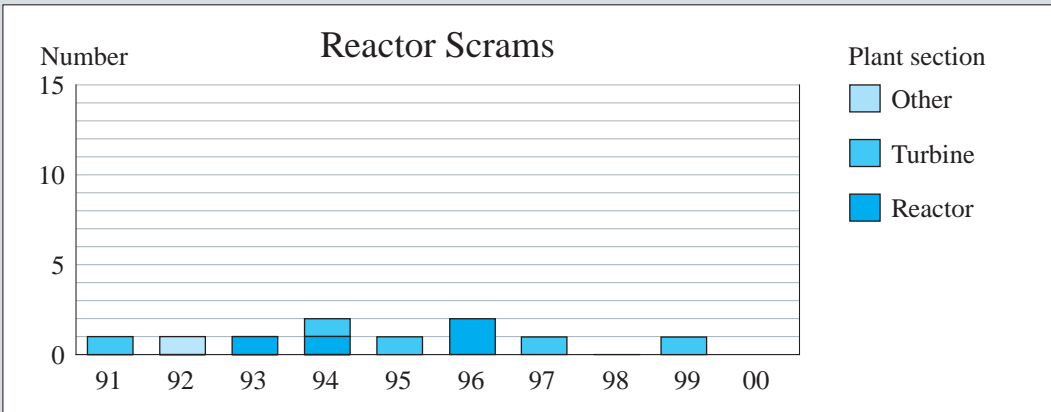
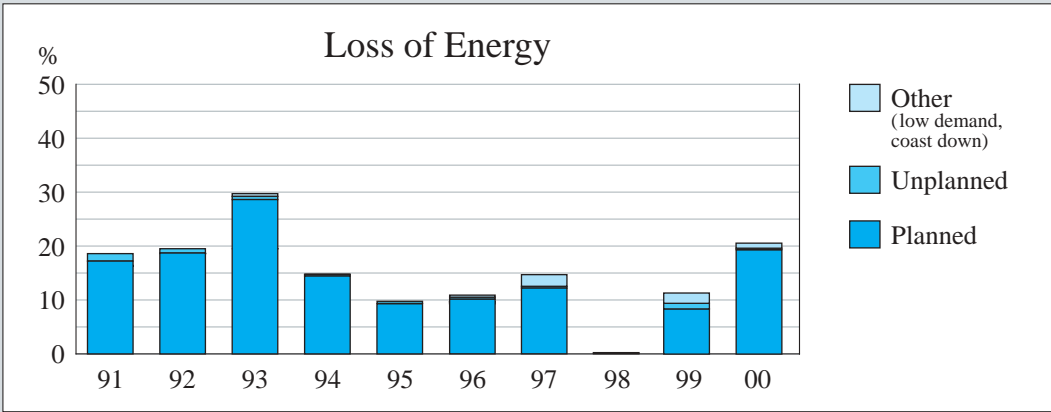
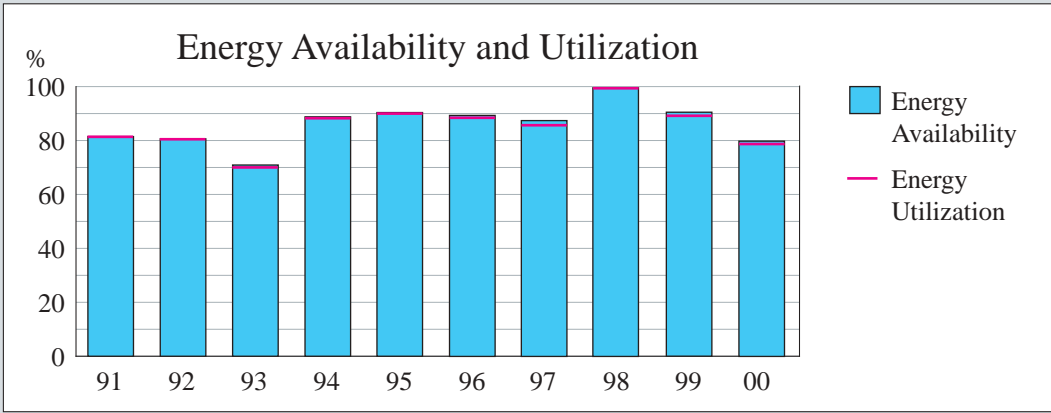

# Beznau 2

## Operating Experience 2000

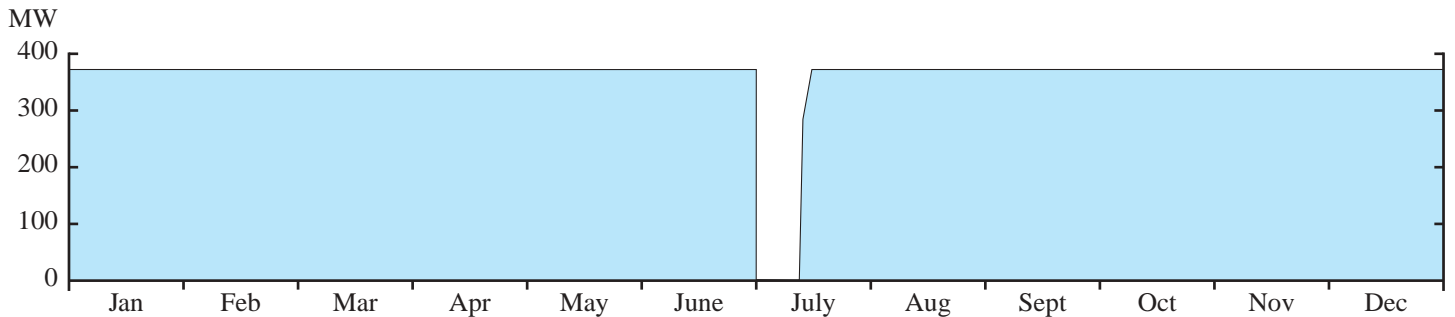

### Important to Safety

#### Scrams:

There were no automatic scrams during power operation.

#### Other:

**December 31:** The millennium calendar change did not cause problems for plant operation. The careful analysis and preparations carried out at the technical level over a period of several years bore fruit. The combination of internal precautionary measures and arrangements made within the energy sector as a whole resulted in an incident-free millennium changeover as in a normal year.

### Important to Availability

**July 1:** The refuelling outage, the first short outage within the scope of the so called hybrid cycle, served primarily the replacement of the irradiated fuel elements. This allowed resumption of power operation after a period of only twelve days on July 13. The hybrid cycle means a first production year with short outage with emphasis on the fuel change and the necessary tests followed by a year with longer outage for the planned maintenance and fuel change. The hybrid cycle utilizes the long experience of plant operations and contractors concerning the behaviour of components and systems and the use of precautionary maintenance aiming to reduce the average outage period without loss of safety. This has a positive effect on the load factor and the power production cost.

# History

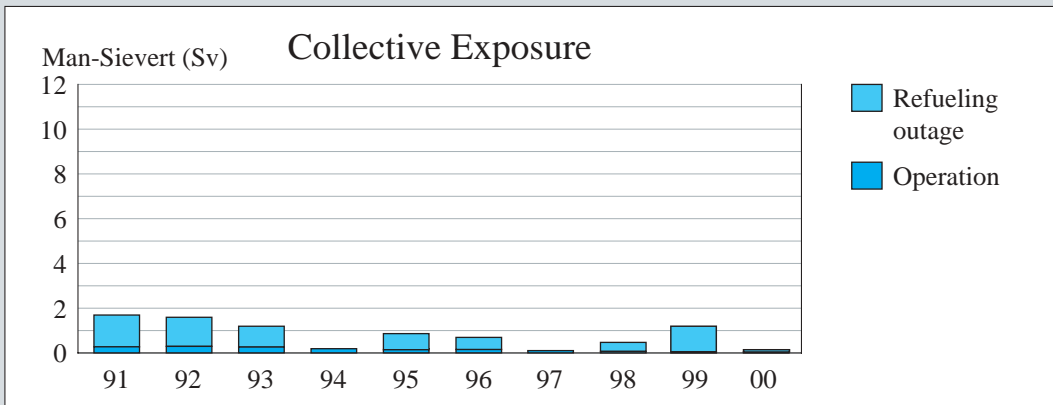
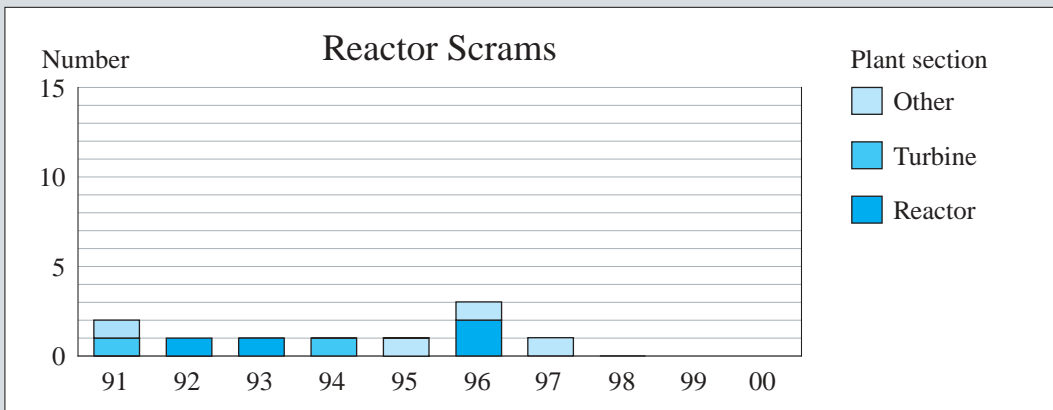
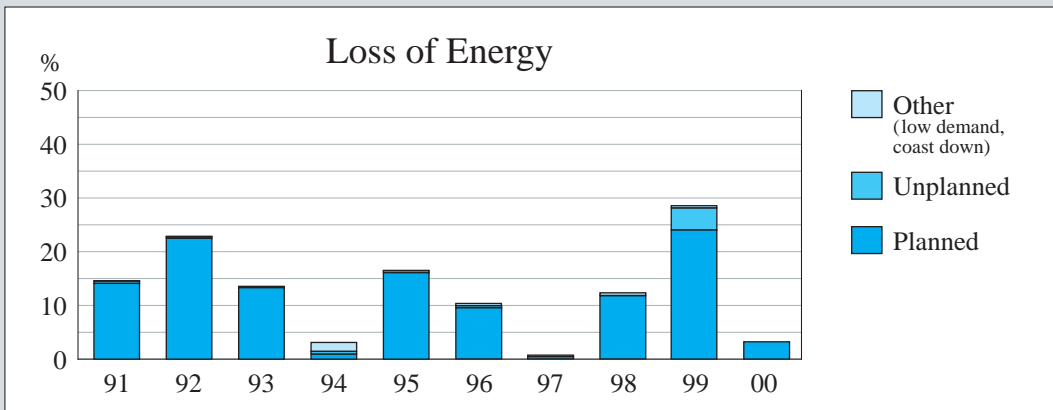
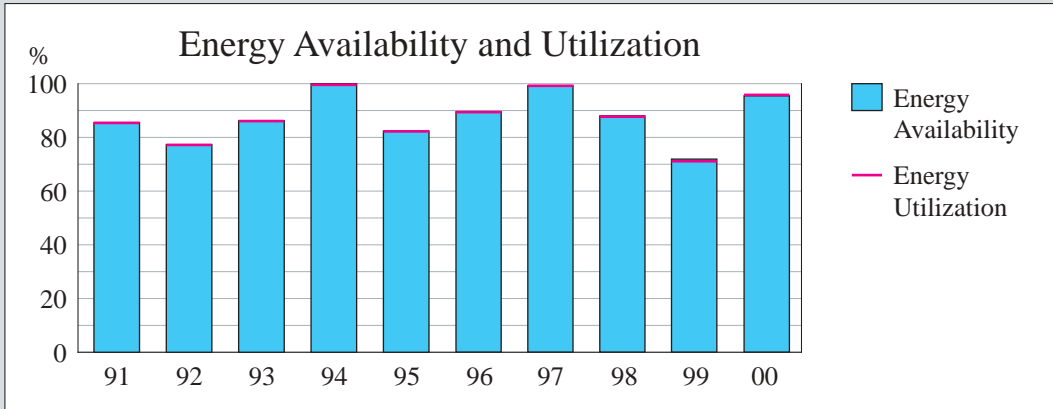

# Characteristics

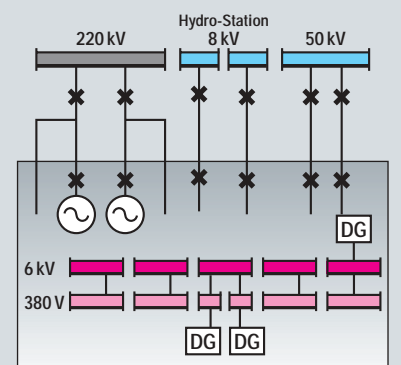
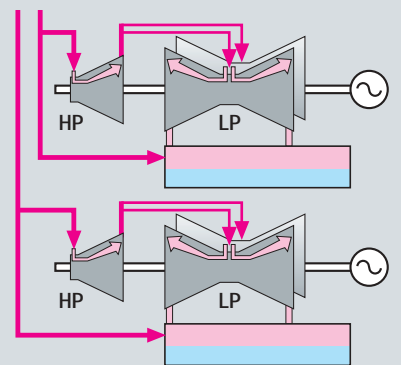
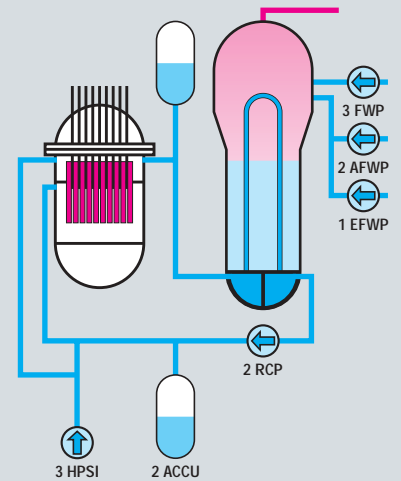
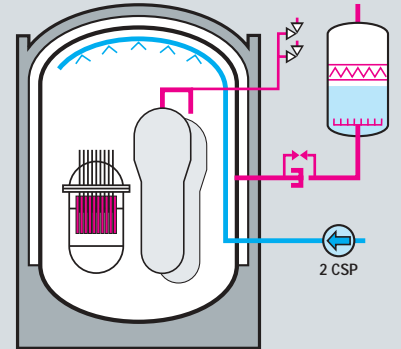

# Mühleberg

## Operating Experience 2000

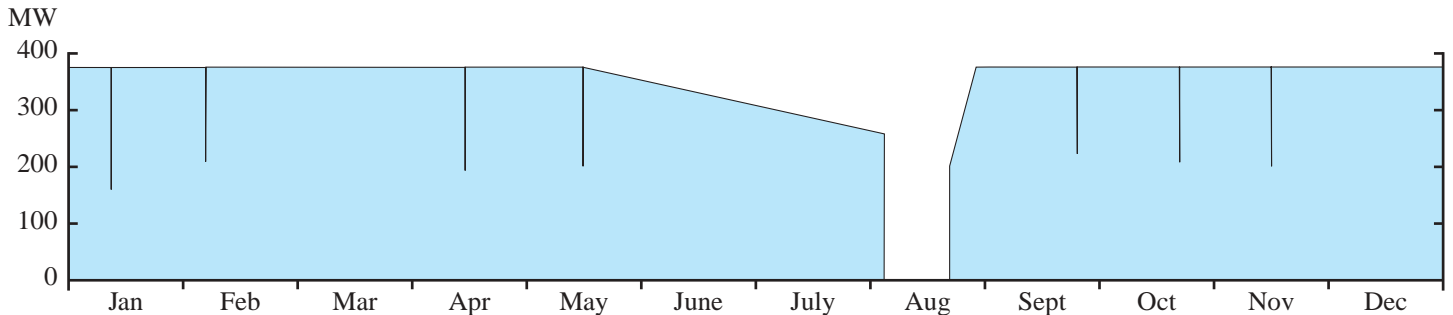

### Important to Safety

#### Scrams:

There were no automatic scrams during power operation.

#### Others:

At the request of the Swiss federal government, an IAEA Operational Safety Review Team (OSART) of international experts visited Mühleberg Nuclear Power Plant from 6th to 23th November 2000. The purpose of the mission was to review operating practices in the areas of management organization and administration, training and qualification, operations, mechanical and electrical maintenance (including plant technical support), radiation protection, chemistry and emergency planning and preparedness.

The team commended the excellent operating history, the plant's conditions and the level of qualification, ownership and motivation of plant staff. It also made suggestions for further improvements in operational safety, as well as recommendations in several other areas.

It identified good practices in several areas including management and organisation.

Hydrogen injection has been applied continuously since October to protect reactor internals.

### Important to Availability

**Mai 17:** The planned coast down operation began. The power at the end of cycle was 72 %.

#### Refueling outage August 4 – August 23:

The planned outage lasted 20 days and included the 2 days necessary to perform a noble metal chemical application to protect reactor vessel internals. In-service inspections and ultrasonics controls of the reactor pressure vessel were successfully carried out. Inspections of core shroud revealed no major change of the crack growth. The electronic control system of the second turbine was replaced. 40 out of 240 fuel elements were replaced by new ones.

#### Load reductions:

A total of 7 load reductions (> one full power hour) were required.

3 unplanned load reductions occurred.

The first one was due to a failure of the speed governor signal of feedwater pump B.

The second one was due to the wear out of main generator set A coal brushes.

The third one was due to a defective throttle valve in the steam line to steam reheater.

2 planned load reductions to 50 % were required for periodical surveillance tests and 2 others planned load reductions were required for change of control rods pattern.

# History

# Characteristics

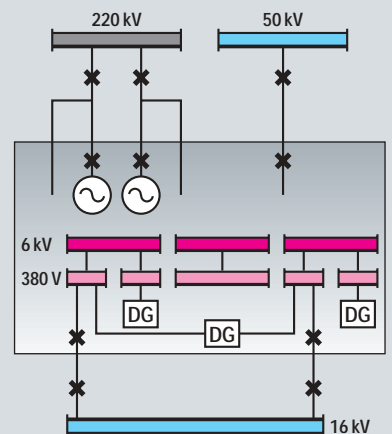
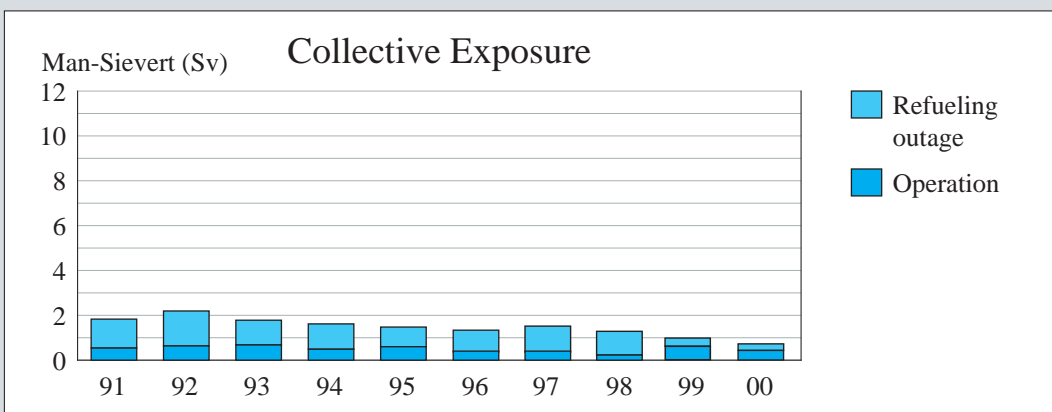
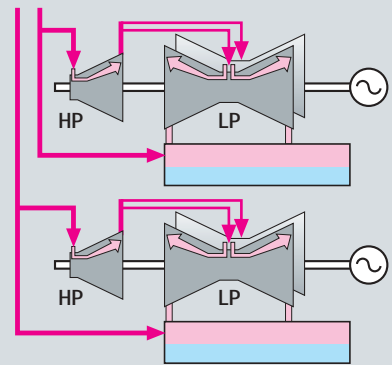
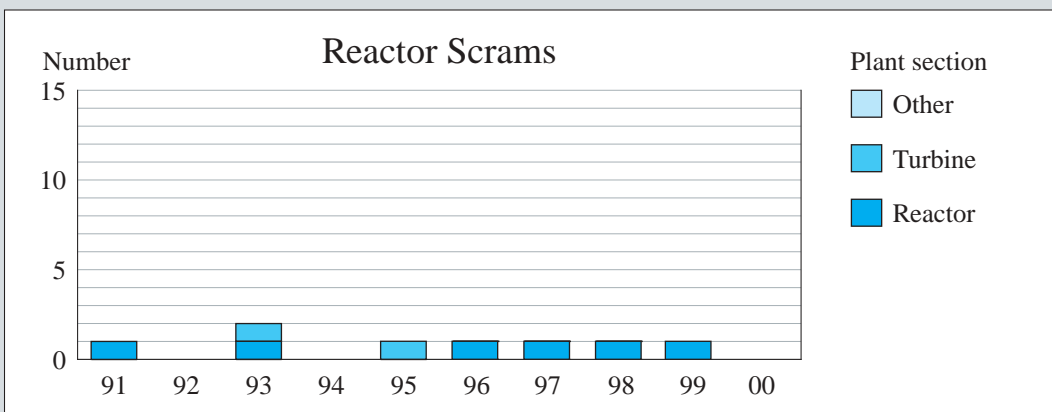
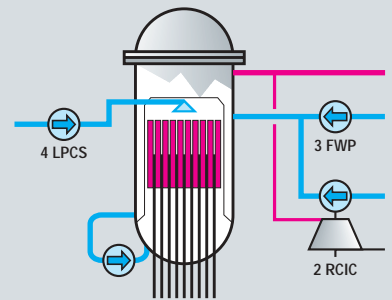
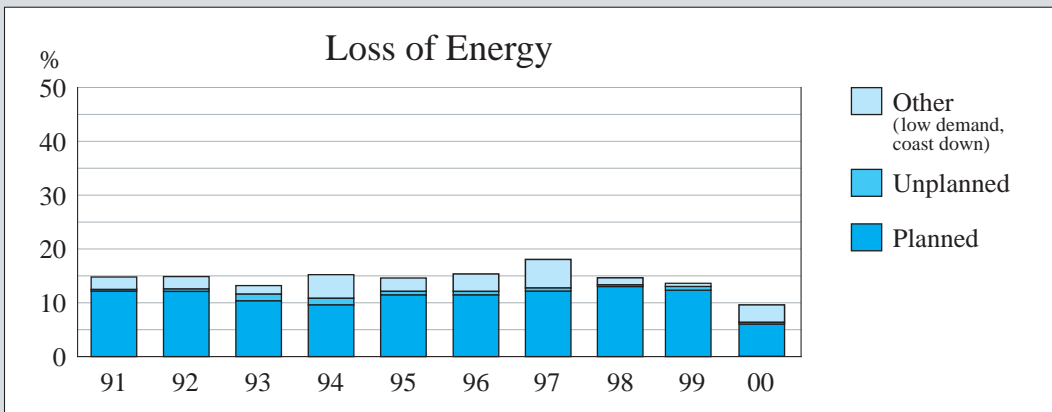
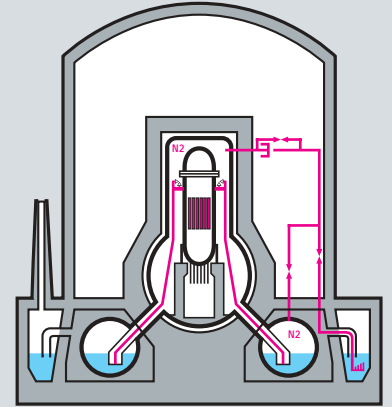
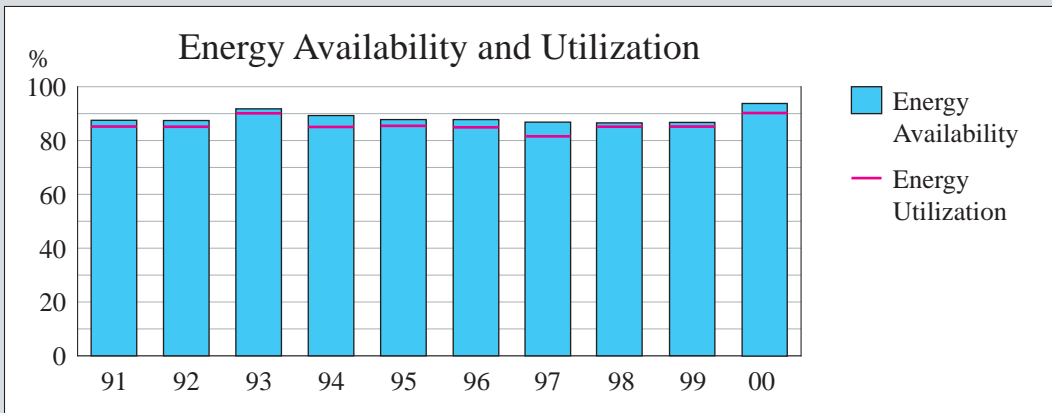

# Gösgen

## Operating Experience 2000

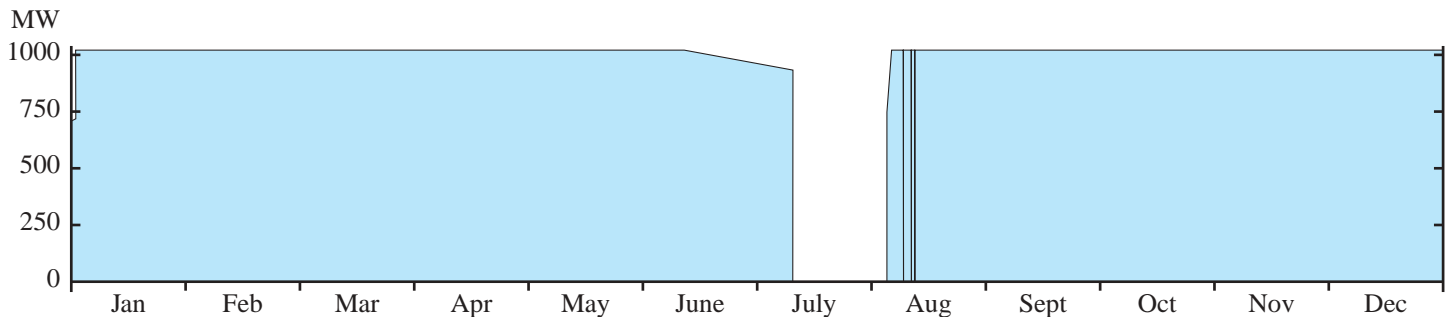

### Important to Safety

#### Scrams:

2000 was the tenth consecutive year of operation without unplanned scrams.

### Important to Availability

**January 1:** Operation at 70 % power for year 2000 contingency.

**February 25:** Bypass-operation of the low pressure preheaters during repair work on a heater drain pump.

**June 11:** Start of coast down operation. The power level at the end of the cycle was 91 %. Coast down operation led to a production loss of about 1.2 equivalent full power days.

#### Refuelling outage, July 8 to August 4:

The refuelling outage was scheduled for 25 days but was extended to 27 days.

In addition to general preventive maintenance and inspection work, the following major work was performed:

- Replacement of the main generator stator.
- Replacement of the shaft seals on two main coolant pumps.
- Replacement of two main steam pressure relief valves.

The valves did not work properly during the functional tests at operating temperature.

The additional work resulted in a two-day extension of the refueling outage.

- Loading of 44 new fuel elements. The newly loaded fuel includes 20 MOX (mixed oxide) and 4 ERU (enriched reprocessed uranium) fuel elements.

**August 9, 11 and 12:** Load reductions to hot shutdown for additional balancing work on the main generator and the exciter in order to correct excessive vibrations.

# History

# Characteristics

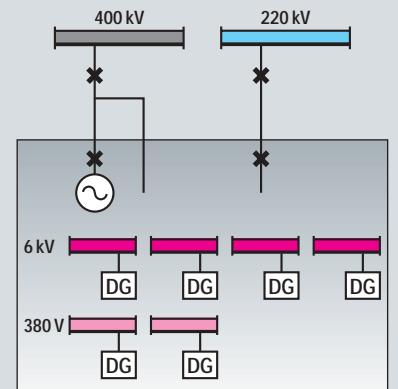
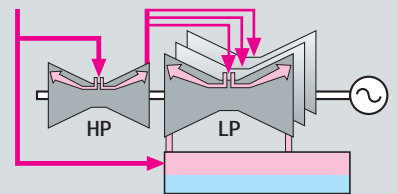
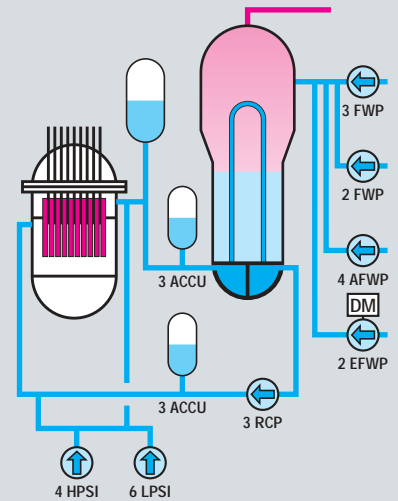
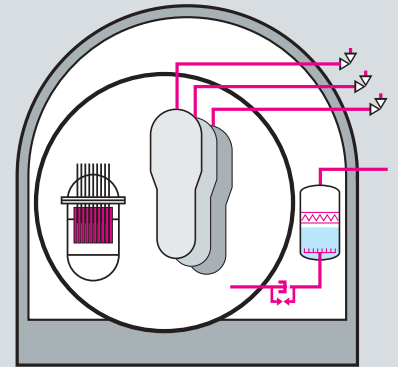
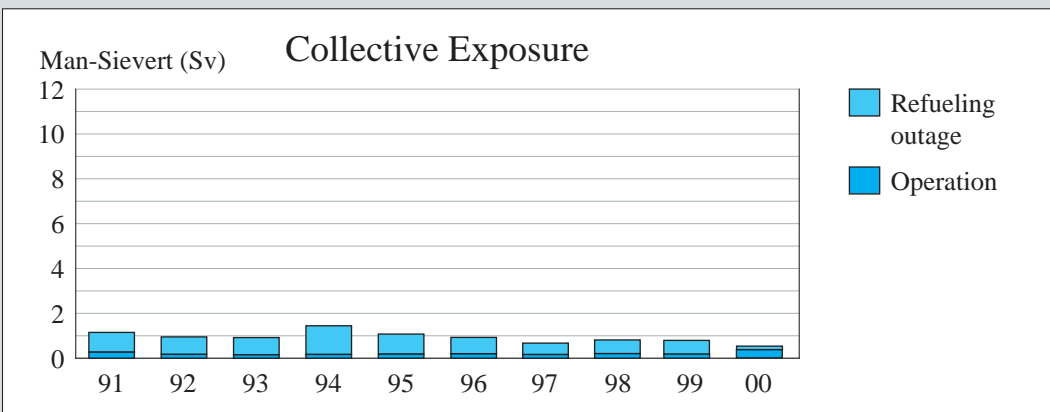
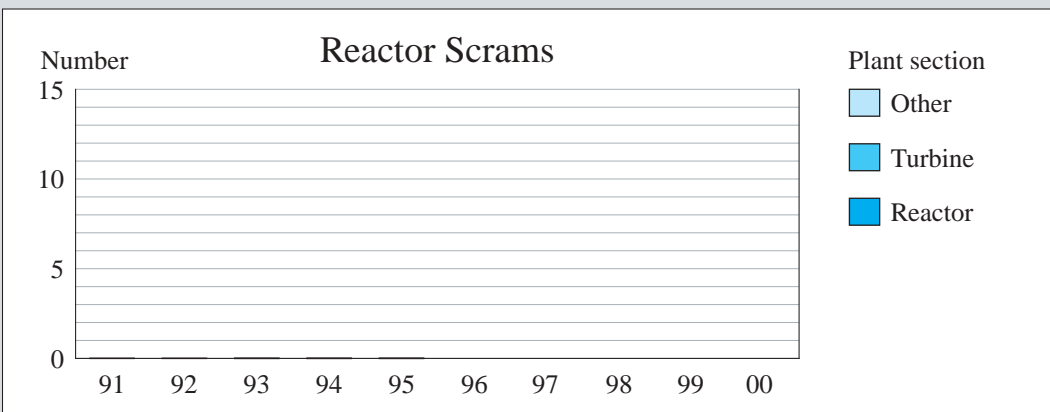
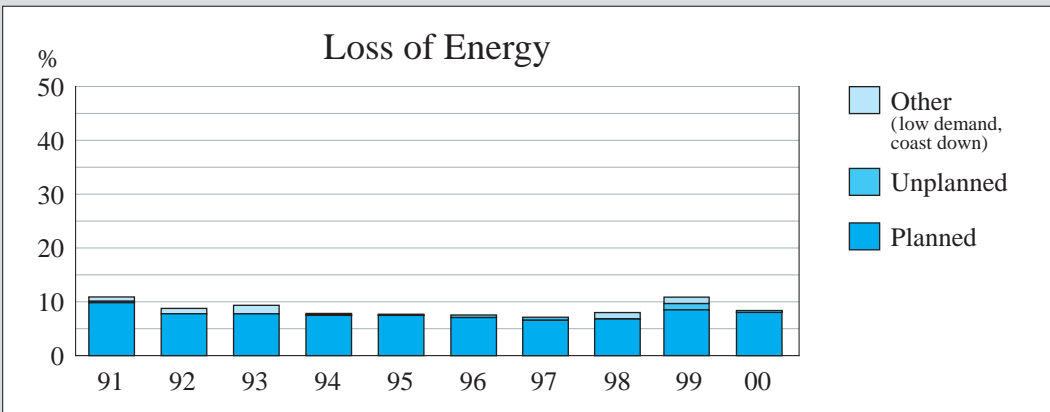
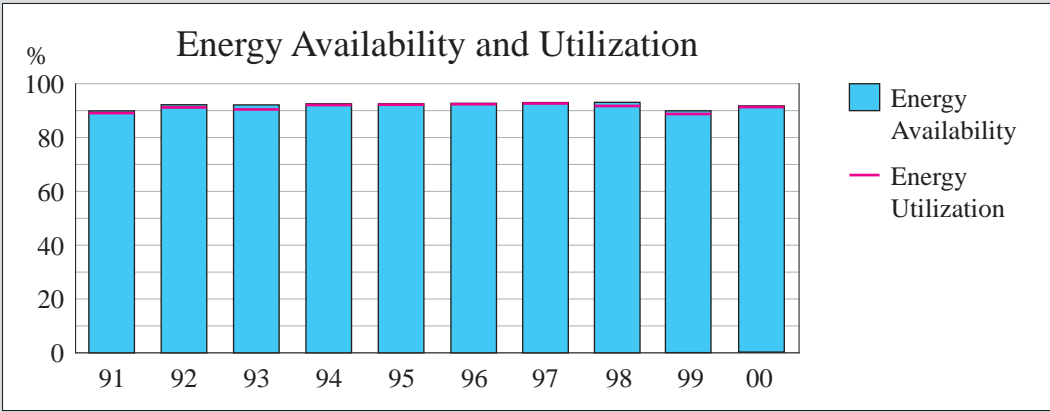

# Leibstadt

## Operating Experience 2000

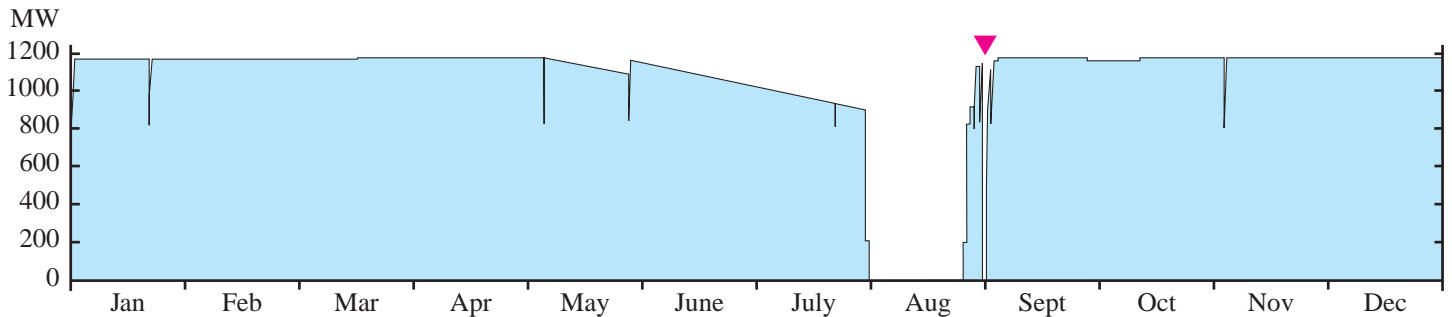

### Important to Safety

#### Scrams:

There was one (1) automatic scram during power operation.

**August 31:** Scram on high reactor water level signal following the failure of a main generator field transformer, designed generator-turbine trips, feedwater system perturbations.

### Important to Availability

**January 1–2:** Load increase after year 2000 contingency load reduction.

**January 22:** Main steam isolation valve (MSIV) monitoring and control rod pattern adjustment.

**March 17:** Planned increase to 109.6 % power.

**May 6:** MSIV monitoring and control rod pattern adjustment.

**May 8:** End-of-cycle coast down.

**May 27:** Control rod pattern adjustment.

**July 22:** MSIV monitoring.

**July 30:** Planned pre-outage load reduction.

**July 31 to Aug. 25: 16th refueling outage**

Duration was 24.7 days (scheduled 21.5).

Loaded 140 new fuel bundles (out of 648).

**August 25 to Sep. 5:** Plant startup; various planned power uprate tests and control rod pattern adjustments.

**August 31:** See scrams.

**September 5:** Increase to 112 % power for power uprate '3 Week Test Period'.

**September 8:** Turbine control valve monitoring.

**September 27:** Reduction to 110 % power after 112 % power '3 Week Test Period' completion.

**October 11:** Planned increase to 112 % power.

**November 4:** MSIV monitoring and control rod pattern adjustment.

# History

# Characteristics

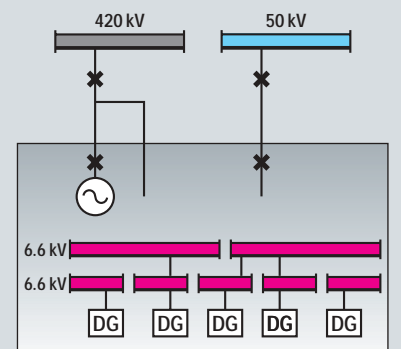
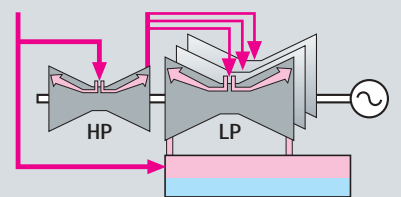
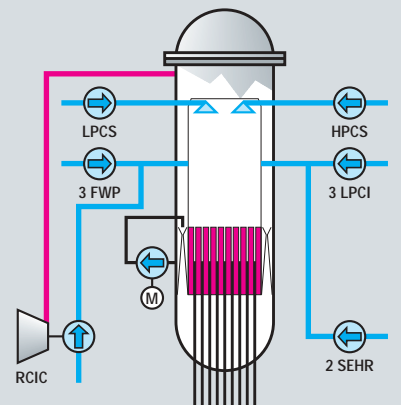
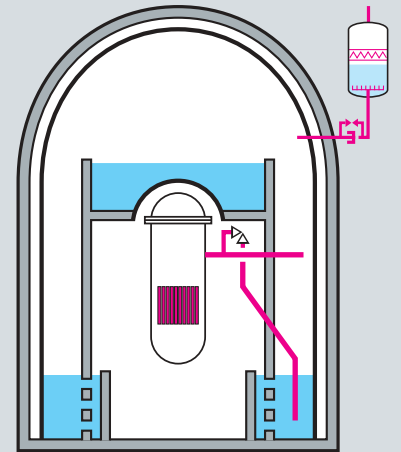
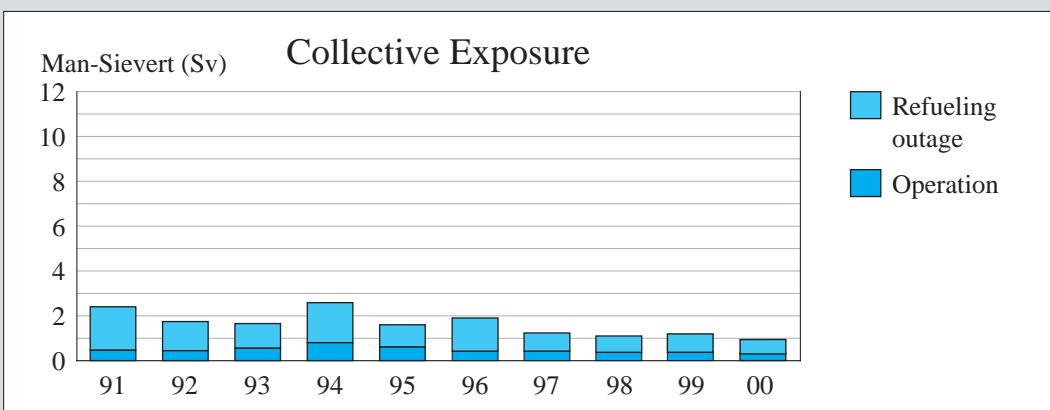
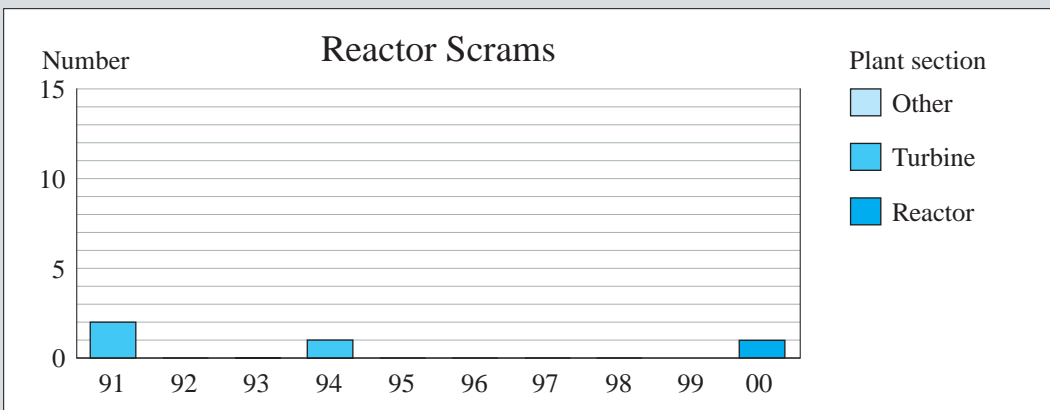
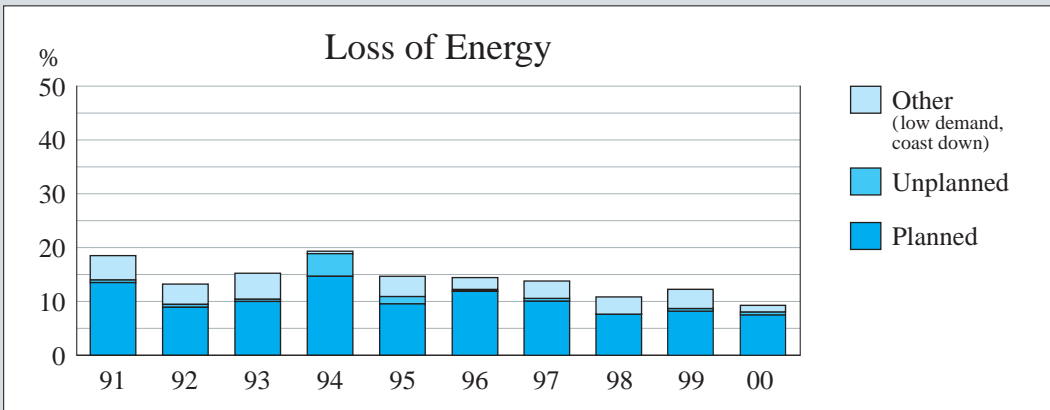
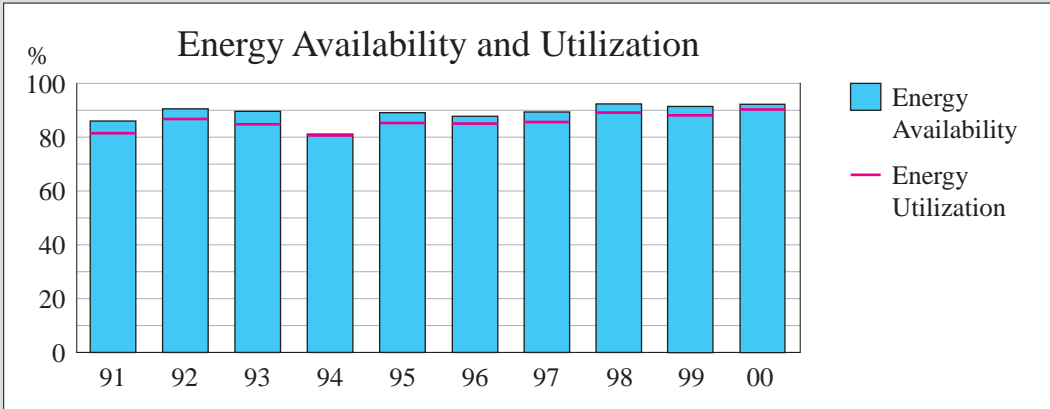

The first two Swiss nuclear power plants, Beznau and Mühleberg, each belong to a single large public electric utility, whereas the two later plants, Gösgen and Leibstadt, are partner plants of several electric utilities and public service companies. The concept of partner nuclear power plants made it possible, when they were set up in the seventies, for medium-sized and smaller organisations to share in economically attractive, large-scale power generation plants and to gain access to the latest technology. In each case one of the partners has responsibility for the business management on behalf of the others.

The Beznau nuclear power plant is fully owned by its operator, Nordostschweizerische Kraftwerke.

Likewise, the Mühleberg nuclear power plant belongs fully to BKW FMB Energie AG.

The partners of Kernkraftwerk Gösgen-Däniken AG (KKG) are:

- Aare-Tessin AG für Elektrizität (ATEL, 35%, managing partner)
- Nordostschweizerische Kraftwerke (NOK, 25%)
- the City of Zurich (15%)
- Centralschweizerische Kraftwerke (CKW, 12.5%)
- the City of Berne (7.5%)
- Swiss Federal Railways (SBB, 5%)

Kernkraftwerk Leibstadt AG (KKL) is owned by the following partners:

- Elektrizitäts-Gesellschaft Laufenburg AG (EGL, 15%, managing partner)
- Aare-Tessin AG für Elektrizität (ATEL, 21.5%)
- Aargauisches Elektrizitätswerk (AEW, 5%)
- Badenwerk AG (BW, 7.5%)
- BKW FMB Energie AG Beteiligungsgesellschaft (BKW/BG, 7.5%)
- Centralschweizerische Kraftwerke (CKW, 12.5%)
- Watt AG, Zürich (5%)
- Kraftwerk Laufenburg (KWL, 7.5%)
- Nordostschweizerische Kraftwerke (NOK, 8.5%)
- S. A. l'Énergie de l'Ouest-Suisse (EOS, 5%)
- Swiss Federal Railways (SBB, 5%)

Copies of this report are available from:  
Swiss Association for Atomic Energy (SVA)

P. O. Box 5032

CH-3001 Berne

Phone +41-31-320 65 25

Telefax +41-31-320 68 31

E-mail: sva@to.aey.ch

<http://www.atomenergie.ch>

<http://www.aspea.ch>



**Nordostschweizerische  
Kraftwerke  
Parkstrasse 23  
CH-5401 Baden  
Phone +41-56-200 31 11**



**BKW FMB Energie AG  
Viktoriaplatz 2  
CH-3000 Berne 25  
Phone +41-31-330 51 11**



**Kernkraftwerk  
Gösgen-Däniken AG  
CH-4658 Däniken  
Phone +41-62-288 20 00**



**Kernkraftwerk Leibstadt AG  
CH-5325 Leibstadt  
Phone +41-56-267 71 11**